

## CH, CHN

Horizontal multistage end-suction pumps  
50/60 Hz

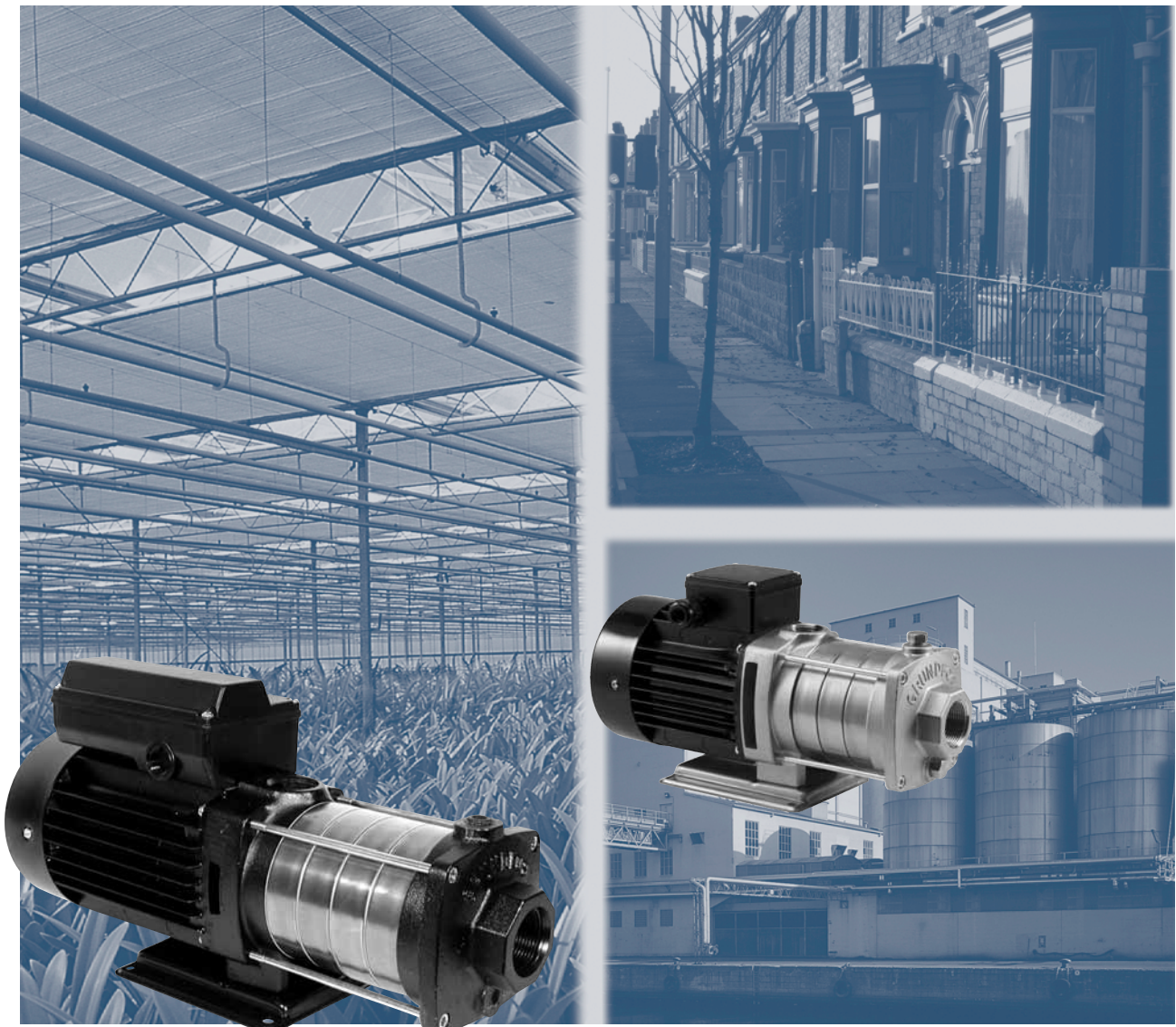

# Contents

---

## General description

Product description	3
Applications	3
Pumped liquids	3
Operating conditions	3
Pump	3
Motor	3
Performance range	4

## Identification

Type key	5
----------	---

## Construction

CH, CHN 2-50	6
CH, CHN 4-60	7
CH 8-50	8
CH 12-50	9
Material specification	10

## Curve charts

Curve conditions	12
How to read the curve charts	13

## Performance curves

CH, CHN 50 Hz	14
CH, CHN 60 Hz	18

## Electrical data

CH, CHN 50/60 Hz	22
------------------	----

## Dimensions and weights

Dimensions	26
CH, CHN 2 and 4 with MG 71/80 motor	26
CH 8 and 12 with MG 80 motor	29
CH 8 and 12 with MG 90 motor	29
Weights	32
CH, CHN, single-phase	32
CH, CHN, three-phase	32

## Further product documentation

WebCAPS	33
WinCAPS	34

## Product description

The Grundfos CH and CHN pumps are non-self-priming, horizontal, multistage, centrifugal pumps.

Pump and motor are integrated in a compact and user-friendly design making the pumps suitable for installation in compact systems.

The pump is fitted with a maintenance-free, mechanical shaft seal and through-going pump-motor shaft.

- **CH:** Chambers as well as all moving parts in contact with the pumped liquid are made of stainless steel. Discharge chamber, suction chamber and base plate are painted non-gloss black.
- **CHN:** Discharge chamber, suction chamber, base plate as well as all parts in contact with the pumped liquid are made of stainless steel.

The motor is painted non-gloss black.

The pump is CE marked.

## Applications

The CH and CHN pumps are designed for small domestic and industrial systems.

### Applications include

- Liquid transfer and circulation of liquids within light industry and farming
- Pressure boosting in single-pump and multi-pump booster systems
- Domestic water supply
- Cooling systems
- Air-conditioning systems.

## Pumped liquids

### CH:

Thin, clean, non-aggressive and non-explosive liquids without solid particles or fibres.

### CHN

Thin, clean, slightly aggressive and non-explosive liquids without solid particles or fibres.

## Operating conditions

Liquid temperature range: 0°C to +90°C.

Max. ambient temperature: +55°C.

The maximum operating pressure depends on the temperature of the pumped liquid, see table:

Max. operating pressure	1 MPa (10 bar)	0.6 MPa (6 bar)
CH 2, CHN 2 CH 4, CHN 4	0°C to +40°C	+41°C to +90°C
CH 8 CH 12	0°C to +55°C	+56°C to +90°C

Min. inlet pressure: According to the NPSH curve plus a safety margin of 0.5 m.

Max. inlet pressure: Limited by the max. operating pressure.

## Pump

The CH, CHN pumps are non-self-priming, horizontal, multistage, centrifugal pumps with mechanical shaft seal and through-going pump-motor shaft. The pumps have axial suction port and radial discharge port and are mounted on a base plate. All movable parts in contact with the pumped liquid are made of stainless steel.

EPDM or FKM O-rings are available as standard.

For pipe connections, see the table:

Connections	CH 2, CHN 2	CH 4, CHN 4	CH 8	CH 12
Axial suction port	Rp 1	Rp 1 Rp 1¼	Rp 1½	Rp 1½
Radial discharge port	Rp 1	Rp 1	Rp 1¼	Rp 1½
Drain hole, priming hole	Rp 3/8	Rp 3/8	Rp ½	Rp ½



TM02 5939 4402

Fig. 1 CH pump

## Motor

The pump is fitted with a totally enclosed, fan-cooled, squirrel-cage Grundfos motor.

Rated speed: 2900 min<sup>-1</sup>

Enclosure class: IP 54

Insulation class: F

Standard voltages: 1 x 220-240 V,  
3 x 220-240/380-415 V

Single-phase motors have built-in thermal overload protection. Three-phase motors must be connected to a motor starter according to local regulations.

## Performance range

### CH, CHN, 50 Hz

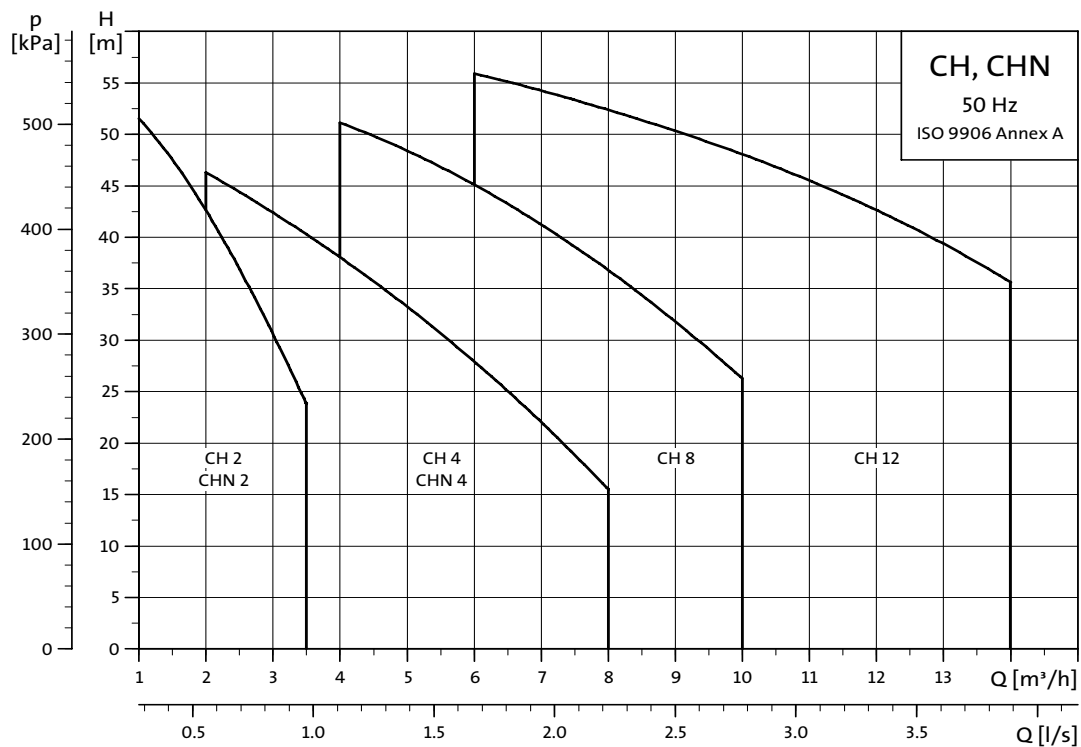

TM02 1239 3603

### CH, CHN, 60 Hz

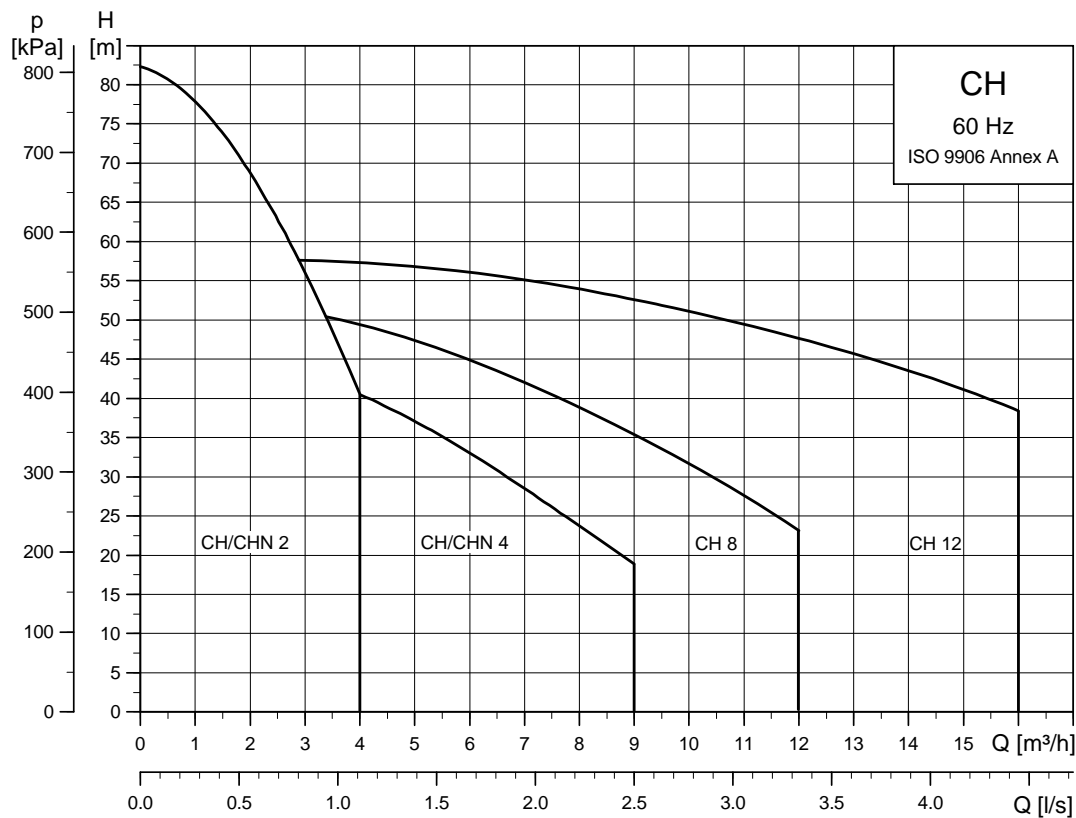

TM02 1240 0701

## Type key

Example	CH(N)	4	-30	A	W	-A	-CVBE
Type range							
Rated flow rate [m <sup>3</sup> /h]							
Max. discharge pressure [m]							
Code for pump version							
Code for physical dimensions							
Code for materials, excluding plastic and rubber parts							
Code for shaft seal							

### Codes for physical dimensions:

- B: NPT pipe connection
- N: Different connection diameters
- W: Whitworth thread, R<sub>p</sub> ISO 7/1
- O: Outside thread.

### Codes for materials:

- A: Basic version
- I: Stainless materials
- X: Special version.

## CH, CHN 2-50

### Sectional drawings

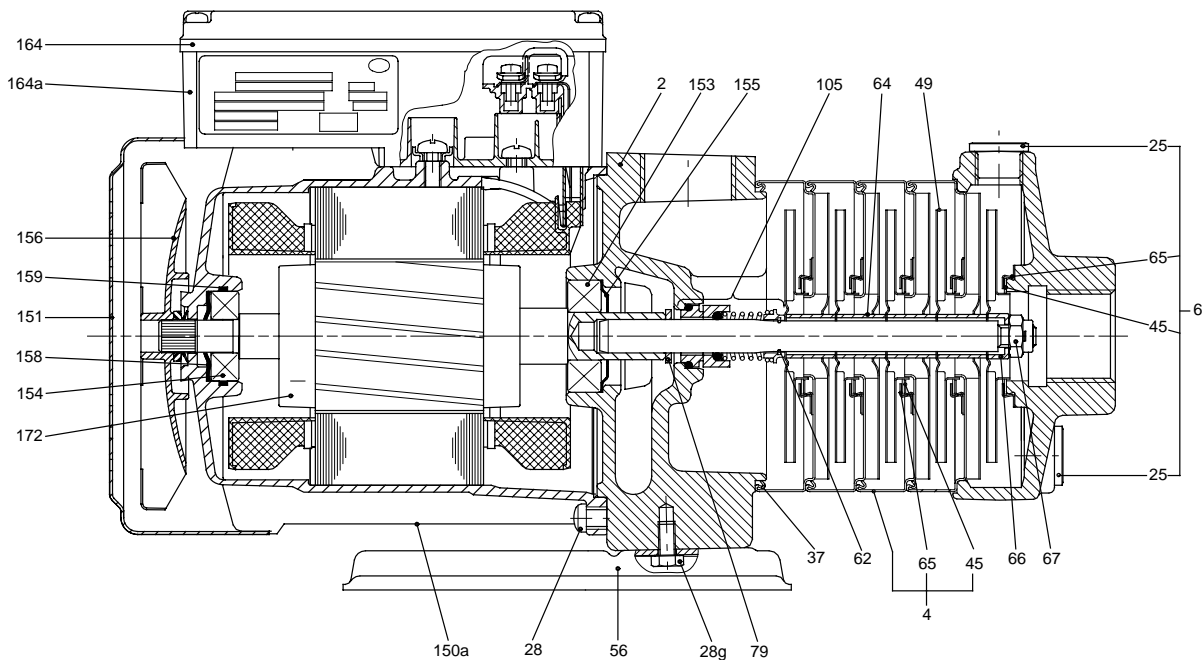

TM03 2039 3504

Fig. 2 CH, CHN 2-50 with MG 71 motor

### Components

Pos.	Component	Pos.	Component	Pos.	Component
2	Discharge chamber	56	Base plate	151	Fan cover
4	Chamber	62	Stop ring	153,154	Ball bearing
6	Suction chamber	64	Spacing pipe	155	Bearing cover plate
25	Plug	65	Retainer for neck ring	156	Fan
28	Screw	66	Clamp	158	Corrugated spring
28g	Hexagon head screw	67	Lock nut	159	O-ring
37	Gasket	79	Diverting disc	164	Terminal box cover
45	Neck ring	105	Shaft seal	164a	Terminal box
49	Impeller	150a	Stator housing	172	Shaft

## CH, CHN 4-60

### Sectional drawing

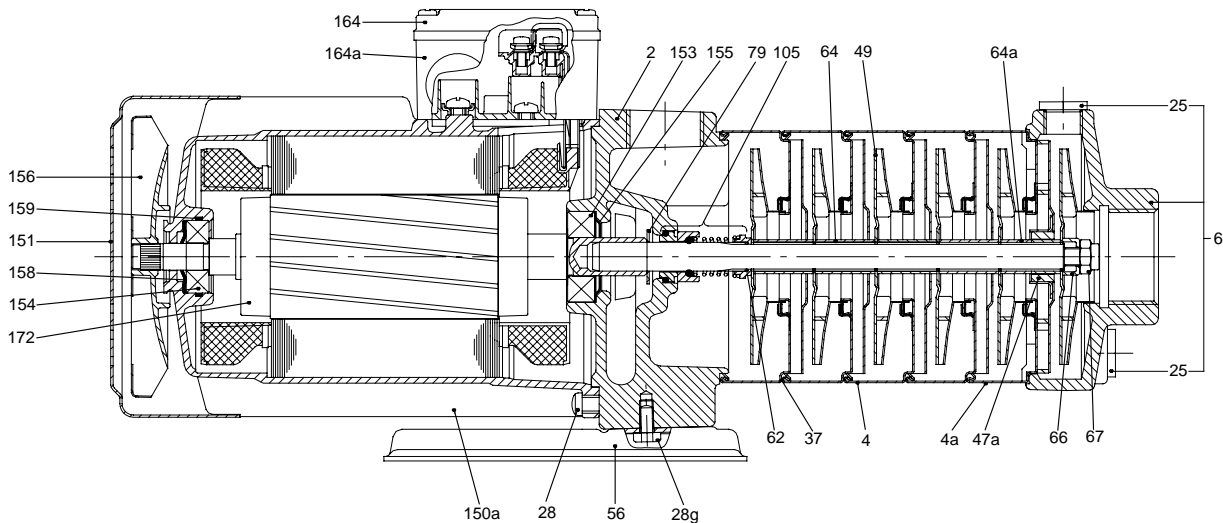

TM00 6609 4900

Fig. 3 CH, CHN 4-60 with MG 80 motor

### Components

Pos.	Component	Pos.	Component	Pos.	Component
2	Discharge chamber	56	Base plate	153,154	Ball bearing
4	Chamber	62	Stop ring	155	Bearing cover plate
4a	Chamber with bearing	64	Spacing pipe	156	Fan
6	Suction chamber	64a	Spacing pipe	158	Corrugated spring
25	Plug	66	Clamp	159	O-ring
28	Screw	67	Lock nut	164	Terminal box cover
28g	Hexagon head screw	79	Diverting disc	164a	Terminal box
37	Gasket	105	Shaft seal	172	Shaft
47a	Bearing	150a	Stator housing		
49	Impeller	151	Fan cover		

## CH 8-50

### Sectional drawing

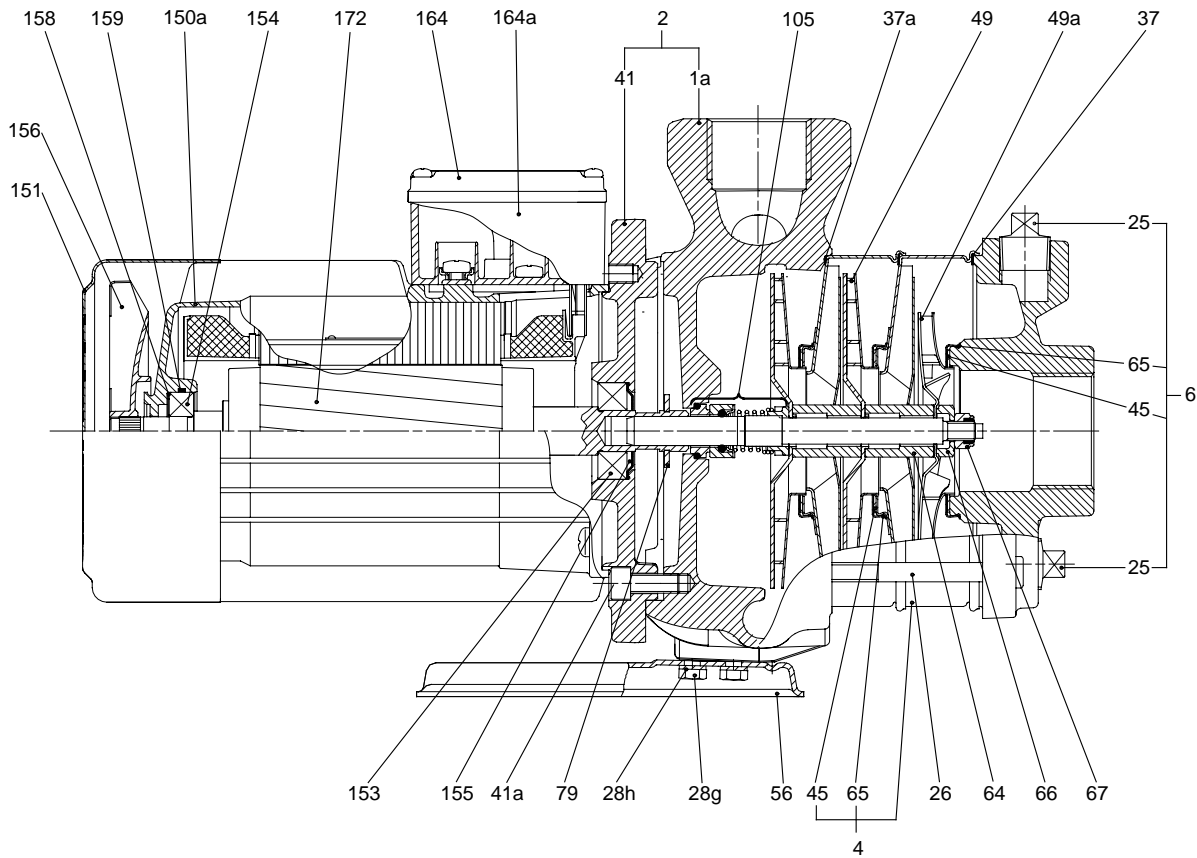

Fig. 4 CH 8-50 with MG 80 motor

### Components

Pos.	Component	Pos.	Component	Pos.	Component
1a	Pump housing	45	Neck ring	151	Fan cover
4	Chamber	49	Impeller	153,154	Ball bearing
6	Suction chamber	49a	Impeller	155	Bearing cover plate
25	Plug	56	Base plate	156	Fan
26	Staybolt	64	Spacing pipe	158	Corrugated spring
28	Screw	65	Retainer for neck ring	159	O-ring
28g	Hexagon head screw	66	Clamp	164	Terminal box cover
28h	Serrated lock washer	67	Lock nut	164a	Terminal box
37	Gasket	79	Diverting disc	172	Shaft
37a	Gasket	105	Shaft seal		
41	Bearing plate	150a	Stator housing		

TM03 2036 3505



## CH 12-50

### Sectional drawing

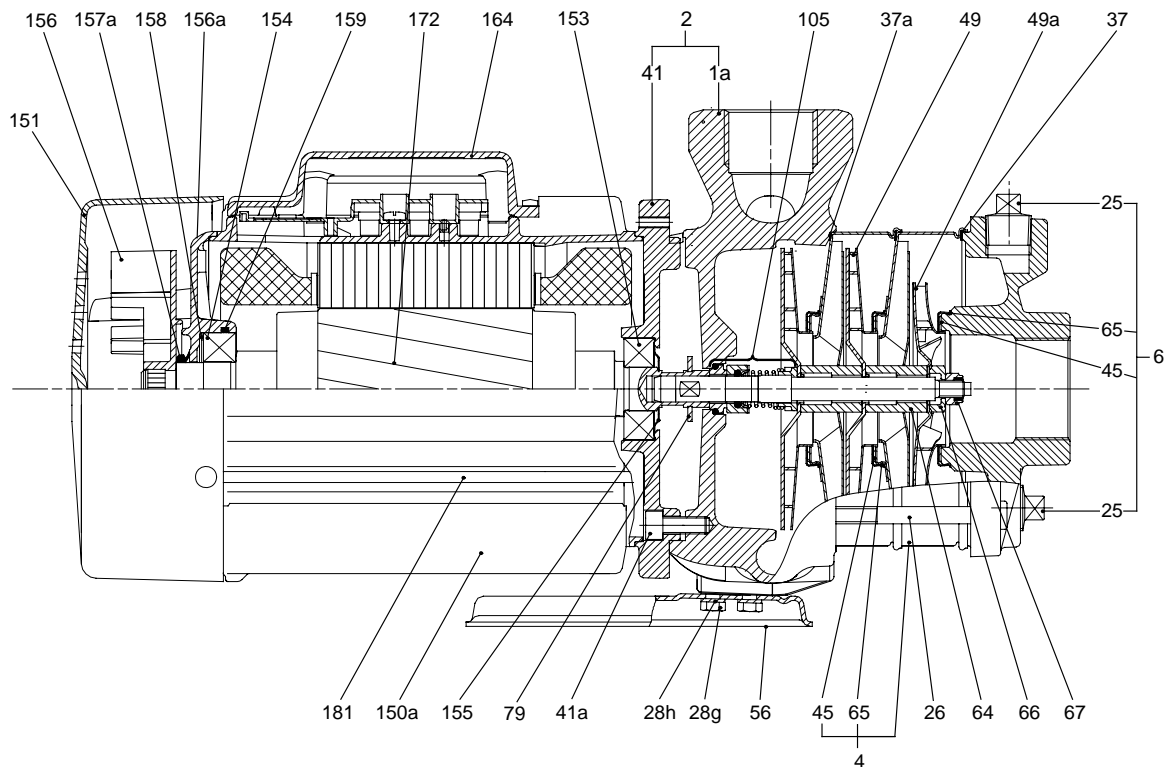

TM03 2037 3505

Fig. 5 CH 12-50 with MG 90 motor

### Components

Pos.	Component	Pos.	Component	Pos.	Component
1a	Pump housing	45	Neck ring	151	Fan cover
4	Chamber	49	Impeller	153,154	Ball bearing
6	Suction chamber	49a	Impeller	155	Bearing cover plate
25	Plug	56	Base plate	156	Fan
26	Staybolt	64	Spacing pipe	156a	Non-drive end shield
28	Screw	65	Retainer for neck ring	157a	Lip seal
28g	Hexagon head screw	66	Clamp	158	Corrugated spring
28h	Serrated lock washer	67	Lock nut	159	O-ring
37	Gasket	79	Diverting disc	164	Terminal box cover
37a	Gasket	105	Shaft seal	172	Shaft
41	Bearing plate	150a	Stator housing	181	Staybolt

## Material specification

Pos.	Description	Material	CH		CHN	
			DIN W.-Nr.	ISO/AISI/ASTM	DIN W.-Nr.	ISO/AISI/ASTM
105	Shaft seal					
<b>Motor parts</b>						
62	Stop ring	Stainless steel	1.4401	AISI 316	1.4401	AISI 316
150	Stator housing complete with terminal box	Silumin/composite (MG 71 and MG 80) Silumin (MG 90)				
150a	Stator housing	Silumin/composite (MG 71 and MG 80) Silumin (MG 90)				
151	Fan cover	Steel (MG 71 and MG 80) Composite PBT/PC (MG 90)	1.0330.3		1.0330.3	
153, 154	Ball bearing					
155	Bearing cover plate	Stainless steel	1.4301	AISI 304	1.4301	AISI 304
156	Fan	Composite PA 66 30% GF				
156a	Non-drive end shield (MG 90)	Silumin				
157a	Lip seal (MG 90)					
158	Corrugated spring					
159	O-ring	NBR rubber				
159a	Gasket					
164	Terminal box cover					
164a	Terminal box					
172	Shaft: pump Shaft: motor	Stainless steel Steel	1.4057 1.0531	AISI 431	1.4057 1.0531	AISI 431
172a	Shaft, complete	Stainless steel/steel	1.4057/ 1.0531	AISI 431	1.4057 1.0531	AISI 431
181	Staybolt (only MG 90)	Steel				
<b>Pump parts</b>						
1a	Pump housing					
2	Discharge chamber	Cast iron/stainless steel	0.6020	ASTM 30 B	1.4308	
4	Chamber	Stainless steel	1.4301	AISI 304	1.4301	AISI 304
4a	Chamber with bearing (CH 4)	Stainless steel + aluminium oxide Al <sub>2</sub> O <sub>3</sub> (ceramic)	1.4301	AISI 304	1.4301	AISI 304
6	Suction chamber, compl.	Cast iron/stainless steel	0.6020	ASTM 30 B	1.4308	
25	Plug	Free-cutting steel/stainless steel	1.0718		1.4301	AISI 304
26	Staybolt	Galvanized steel				
28	Screw					
28g	Hexagon head screw					
28h	Serrated lock washer					
37, 37a	Gasket	Synthetic-fibre-reinforced rubber (NBR)				
41	Bearing plate					
45	Neck ring	PTFE				
47a	Bearing (shaft) (CH 4-60)	Chromium-nickel-molybdenum- cemented tungsten carbide				
49	Impeller CH 8 and 12: ø130 CH, CHN 4: ø95 CH, CHN 2: ø90	Stainless steel	1.4301	AISI 304	1.4301	AISI 304
49a	Impeller CH 8 and 12: ø98	Stainless steel	1.4301	AISI 304	1.4301	AISI 304
56	Base plate	Iron/stainless steel	1.0330.3		1.4301	AISI 304
64, 64a	Spacing pipe	Stainless steel	1.4401	AISI 316	1.4401	AISI 316
65	Retainer for neck ring	Stainless steel	1.4301	AISI 304	1.4301	AISI 304
66	Clamp	Stainless steel	1.4401	AISI 316	1.4401	AISI 316
67	Lock nut	Stainless steel	1.4301	AISI 304	1.4301	AISI 304
79	Diverting disc	NR rubber				



## Curve conditions

The guidelines below apply to the curves on the following pages:

- Tolerances according to ISO 9906, Annex A.
- The **bold** curves state the **recommended** performance range.
- The thin curves are only intended as a guide.
- The curves must not be used as guarantee curves.
- All curves are based on measurements at:
  - 1 x 230 V, 50 Hz
  - 3 x 400 V, 50 Hz
  - 1 x 220 V, 60 Hz
  - 3 x 380 V, 60 Hz.
- When the motor is running at the lowest or highest rated voltage, the pump performance will usually vary by  $\pm 0.5 - 1.0$  m at a given duty point.
- Specific minimum performance requirements necessitate individual measurements.
- The measurements have been made with airless water at a temperature of 20°C (~70°F).
- The conversion between head H (m) and pressure p (kPa) applies to a water density of  $\rho = 1000$  kg/m<sup>3</sup>.

The curves apply to a kinematic viscosity of  $\nu = 1$  mm<sup>2</sup>/s (1 cSt)

## How to read the curve charts

### Curves

- QH: Pump performance at actual speed.
- $P_1$ : Motor input.
- Eta 1: Total efficiency, i.e. pump with motor, is shown in the curve charts as Eta 1.
- NPSH: Average values for all variants shown in chart 1. When sizing, make a safety allowance of at least 0.5 m.

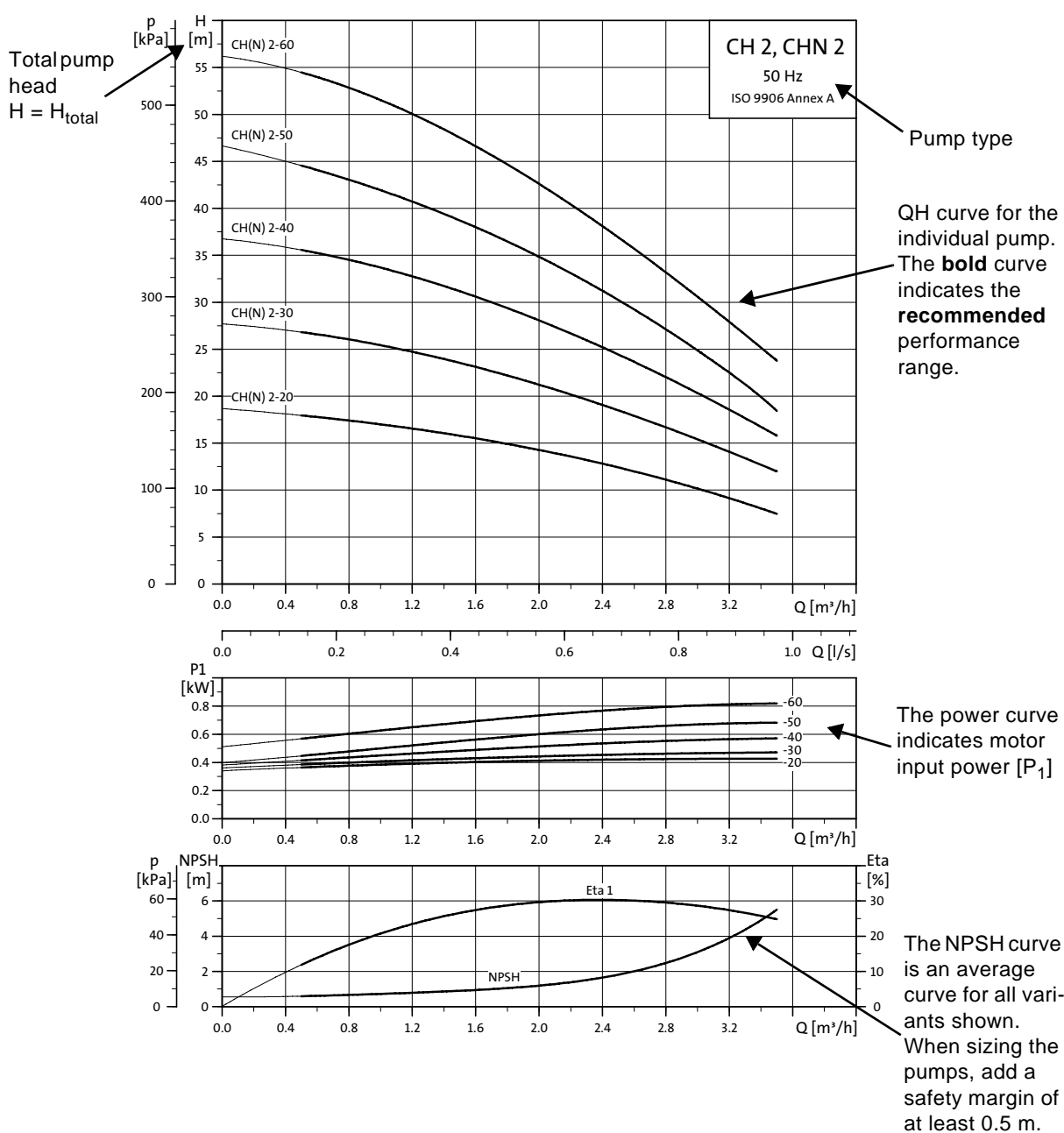

TM00 9319 0499

## CH, CHN 50 Hz

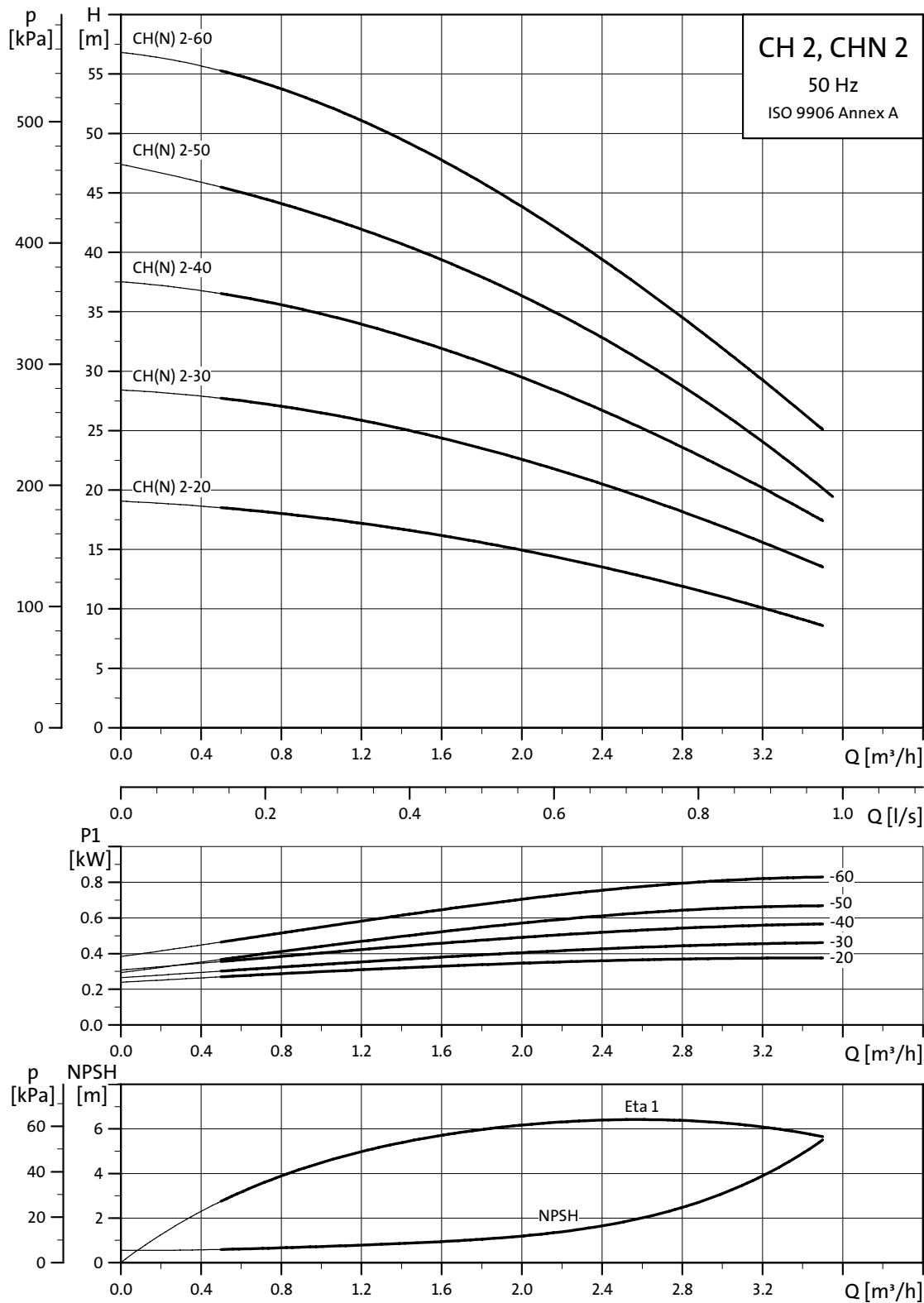

TM02 0380 3302

# Performance curves

CH 4, CHN 4  
50 Hz

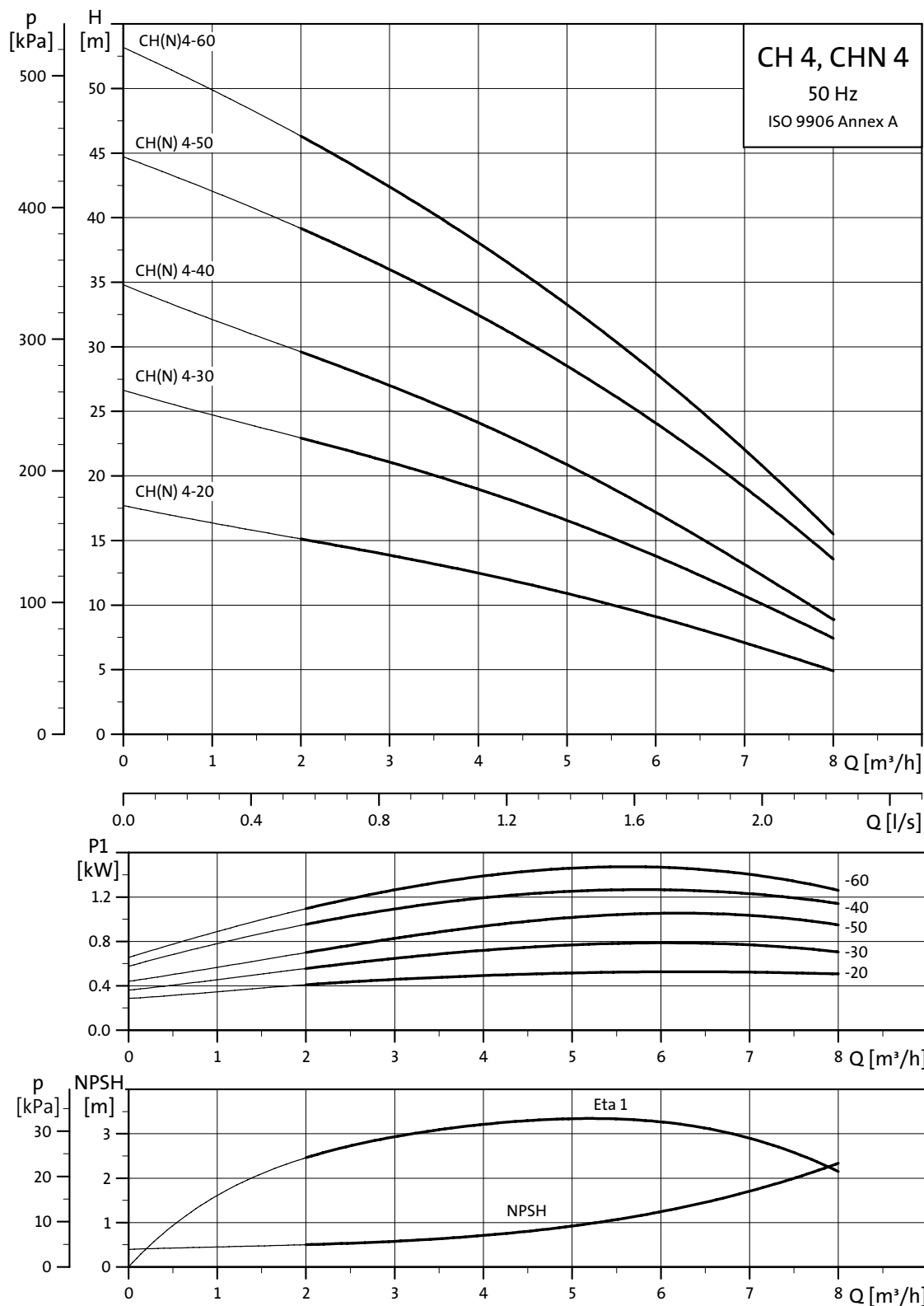

TM02 0390 3302

# Performance curves

CH 8  
50 Hz

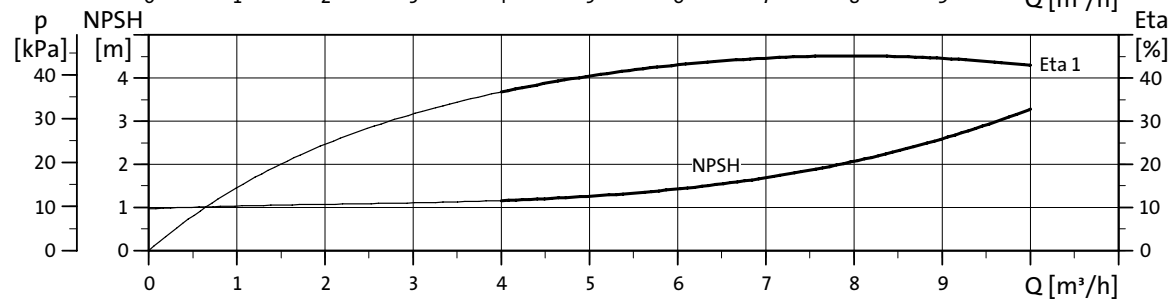
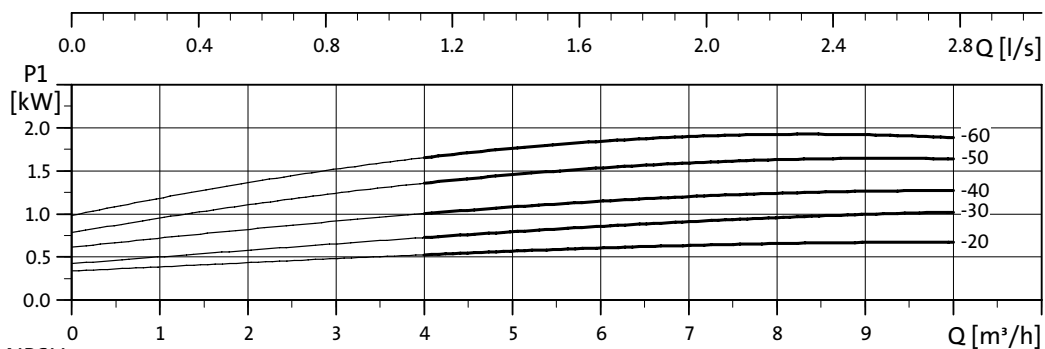
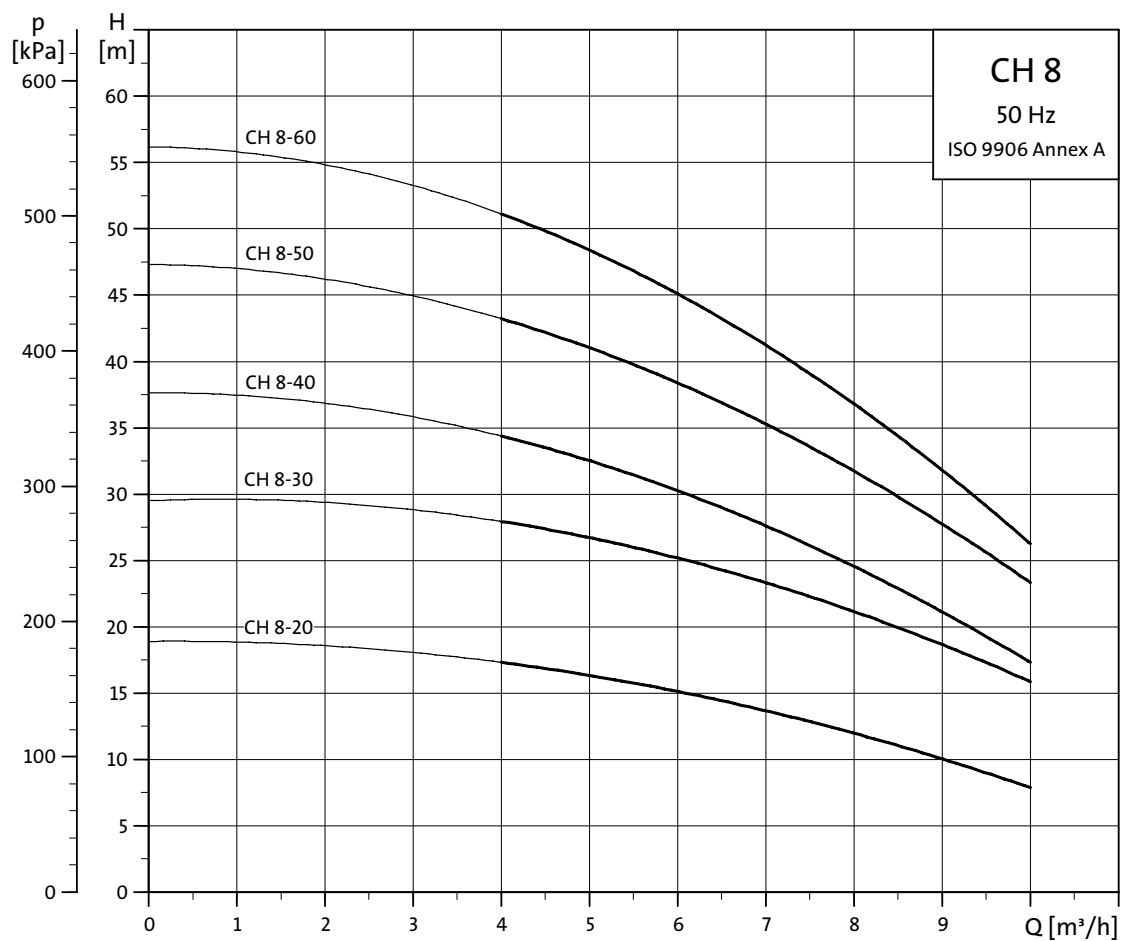

TM02 0398 3603



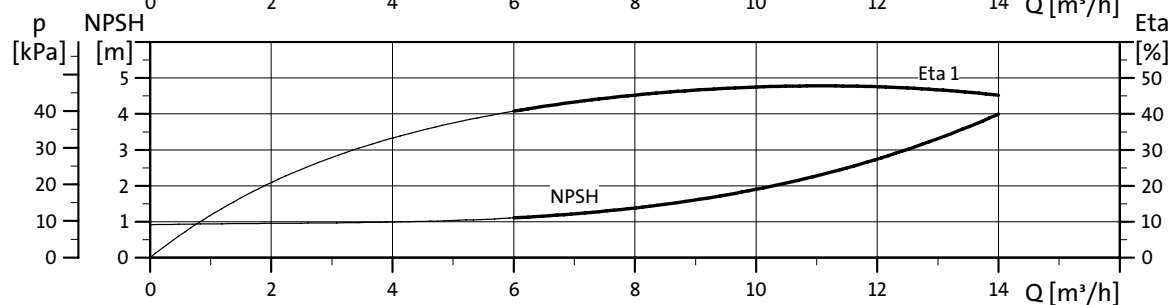
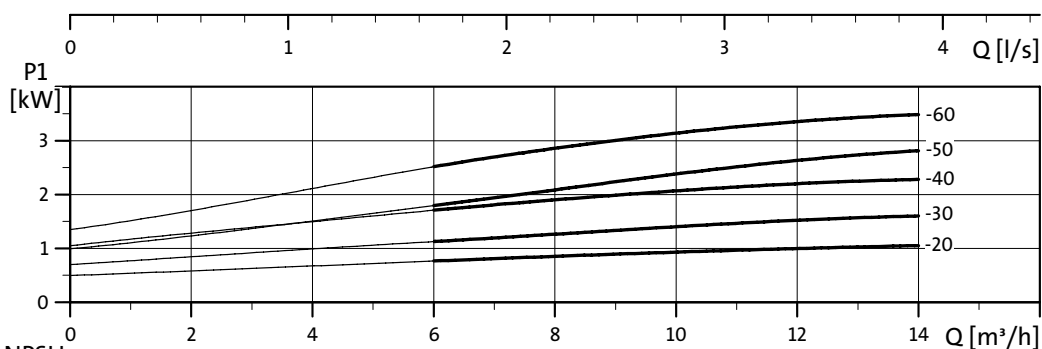
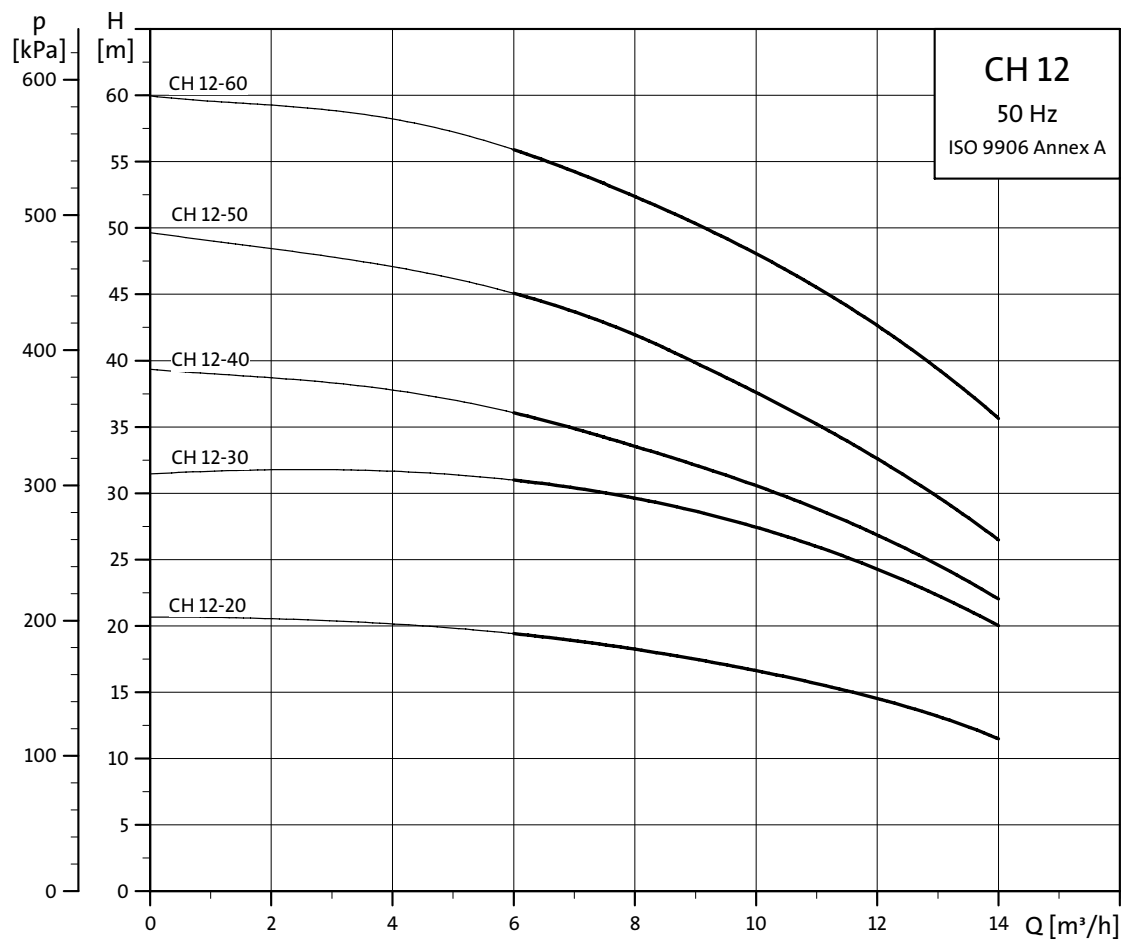

TM02 0406 4400

## CH, CHN 60 Hz

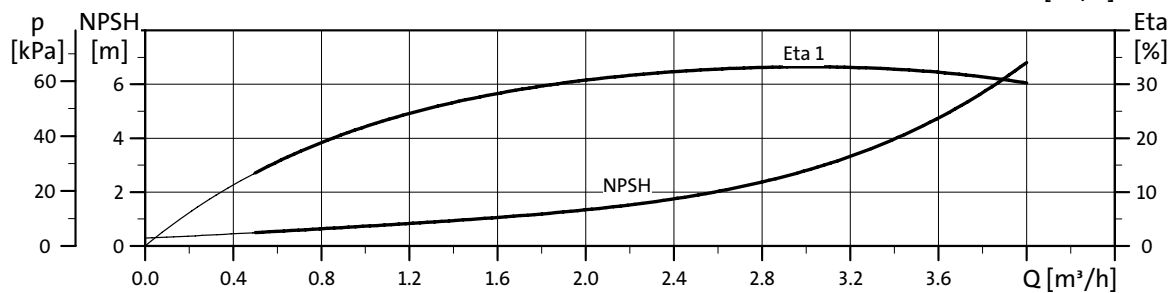
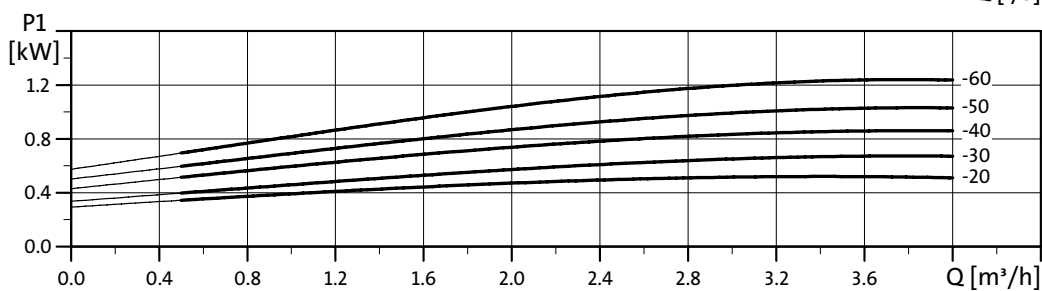
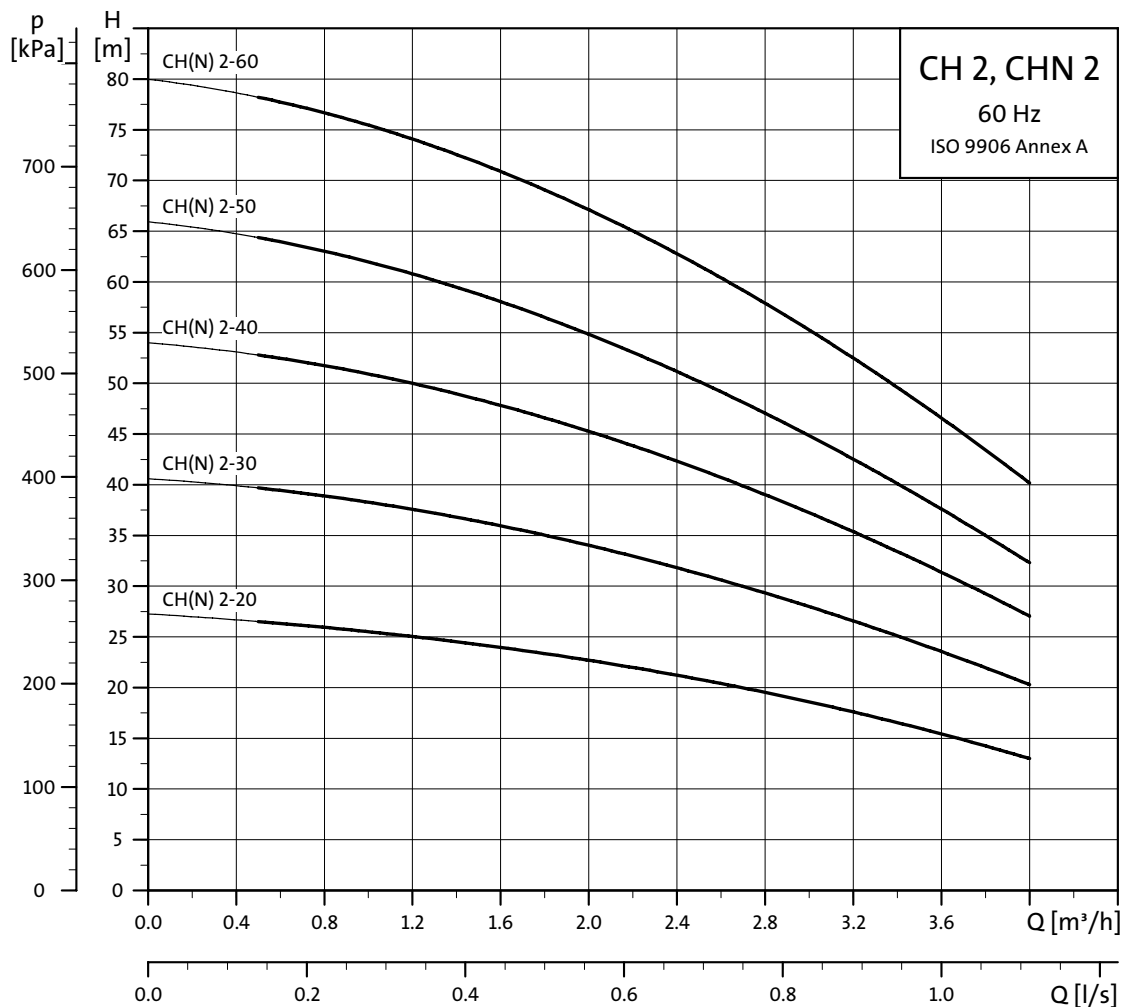

TM02 0382 3302

# Performance curves

CH 4, CHN 4  
60 Hz

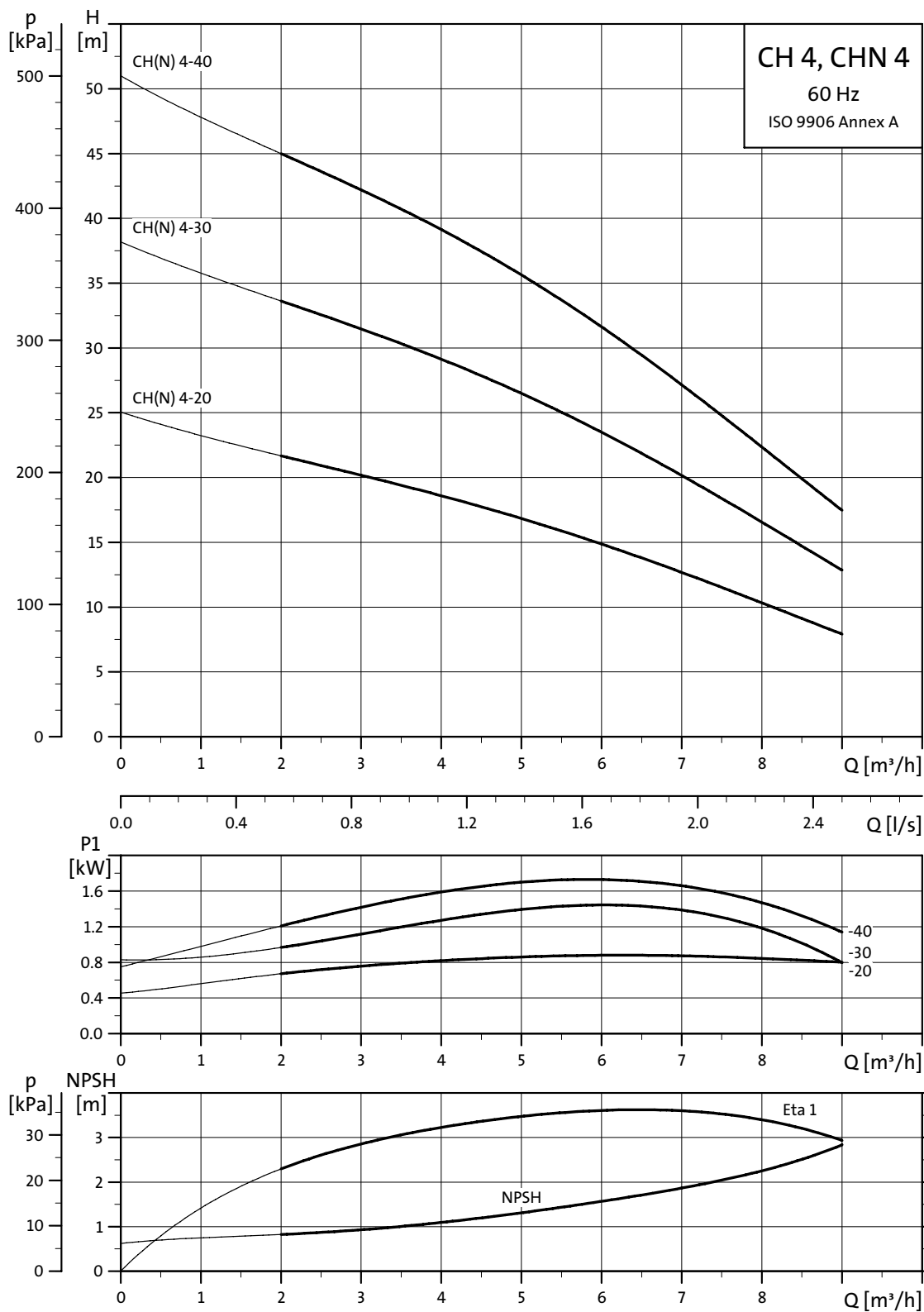

TM02 0392 3302

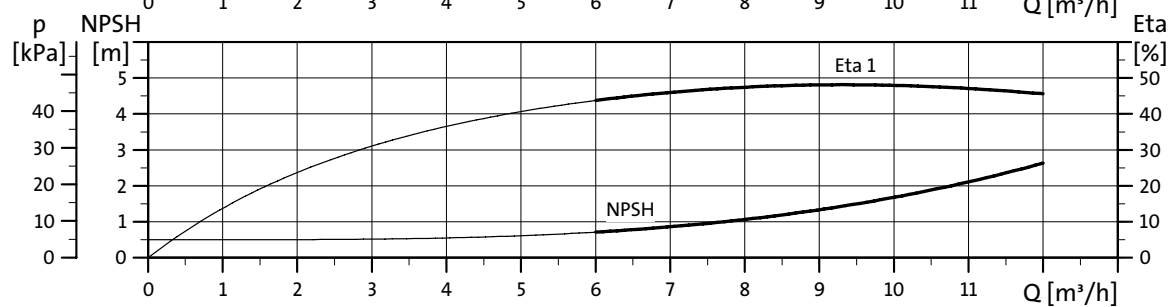
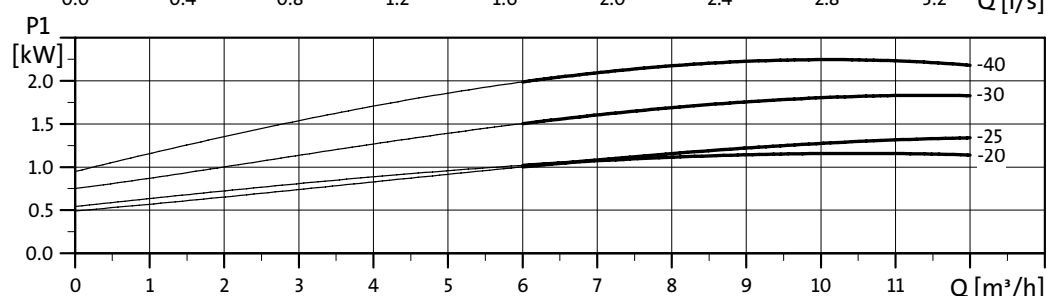
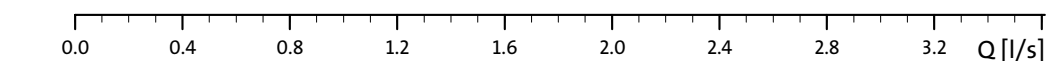
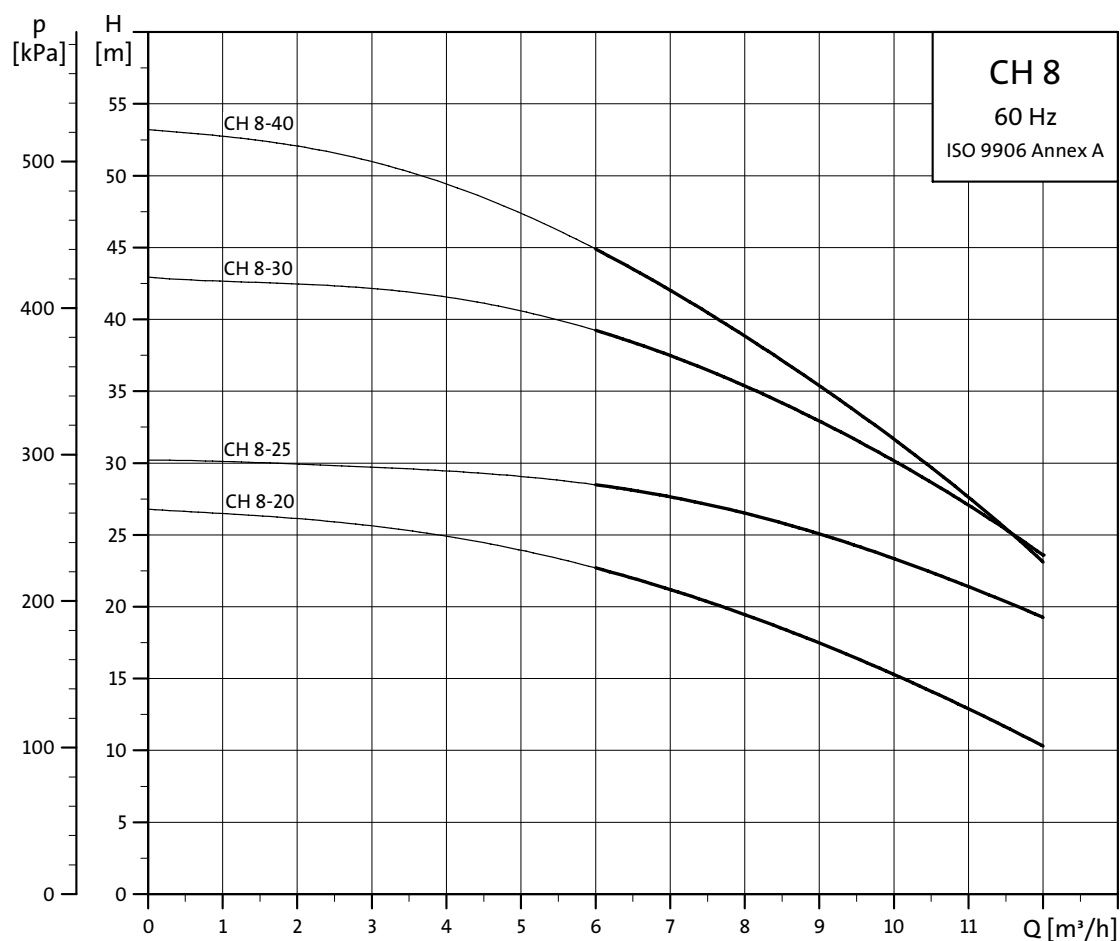

TM02 0400 4400

# Performance curves

CH 12  
60 Hz

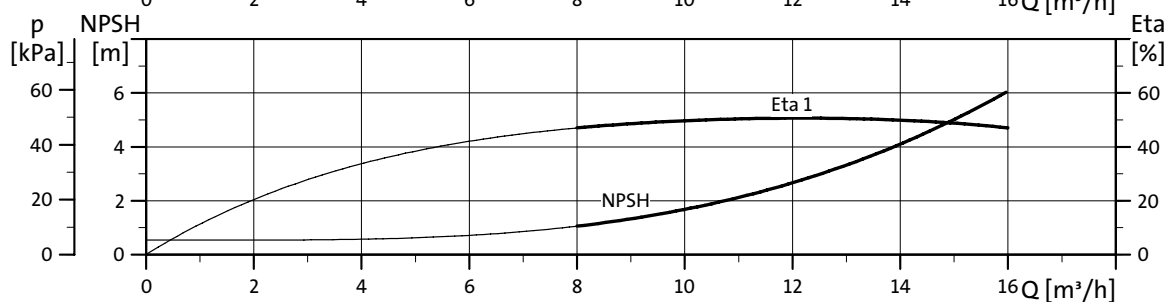
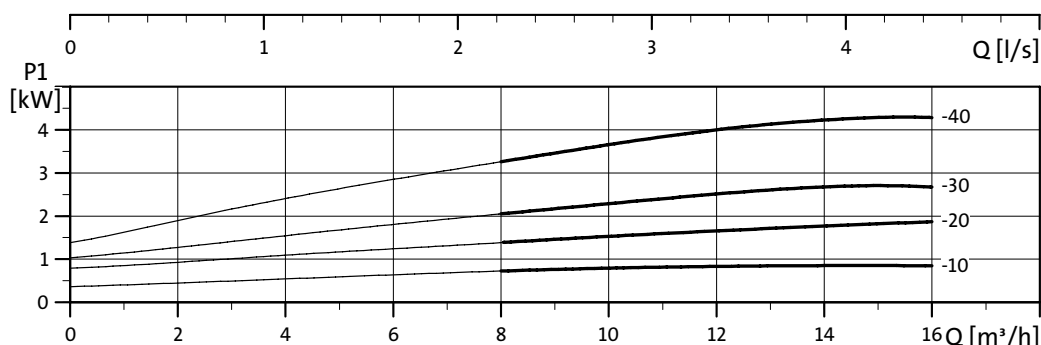
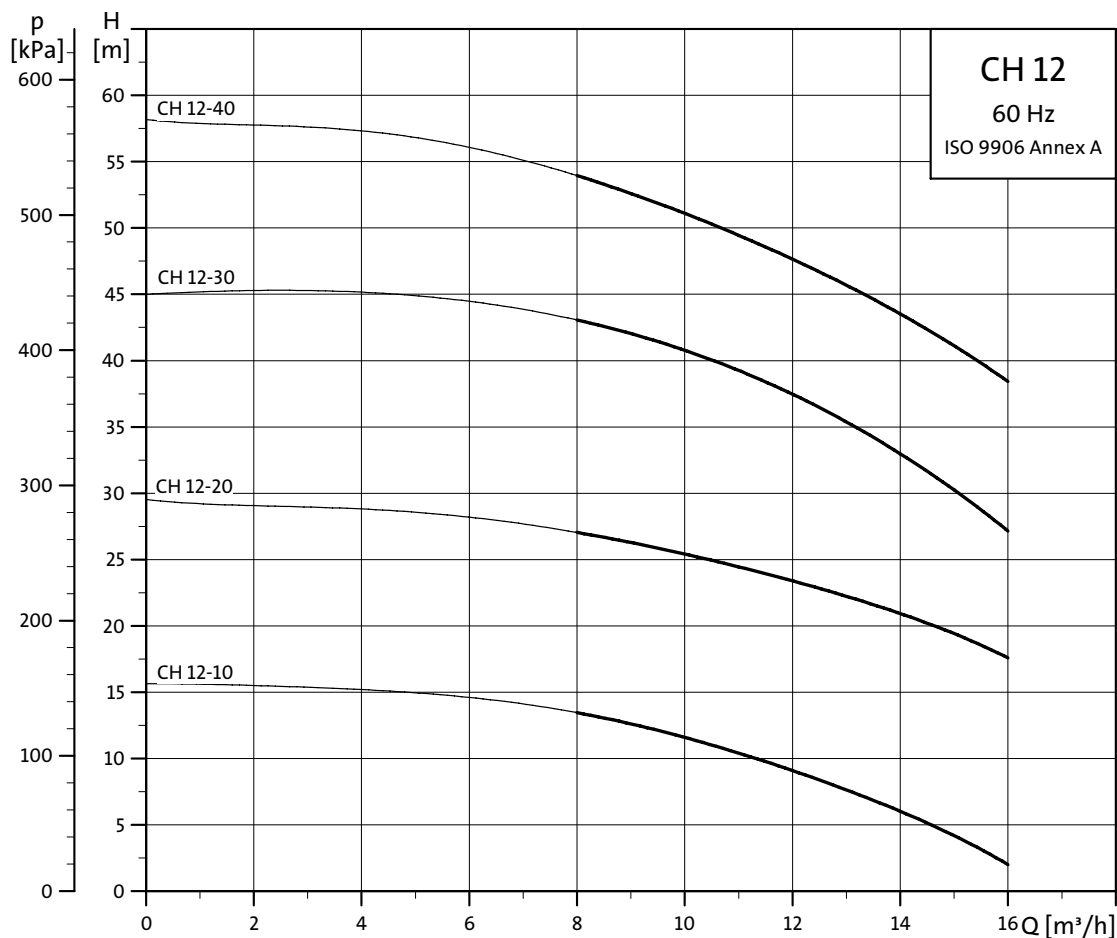

TM02 0390 3302

## CH, CHN 50/60 Hz

$I_{1/1}$  indicates maximum rated current within the voltage range.

$I_{st}$  indicates maximum locked rotor current within the voltage range.

$P_1$  is the maximum motor input.

$P_2$  is the maximum motor output.

### CH, CHN 2

Voltage [V]	Frequency [Hz]	Pump type	Motor type	$I_{1/1}$ [A]	$I_{st}$ [A]	$P_1$ [W]	$P_2$ [W]	C [μF/V]
1 x 220-240	50	CH, CHN 2-20	MG 71	2.2	10.5	420	205	10/400
		CH, CHN 2-30	MG 71	2.3	10.5	480	280	10/400
		CH, CHN 2-40	MG 71	2.6	10.5	570	370	10/400
		CH, CHN 2-50	MG 71	2.9	10.5	680	450	10/400
		CH, CHN 2-60	MG 71	3.7	13	800	560	16/400
1 x 110	60	CH, CHN 2-20	MG 71	6.6	29	690	350	20/400
		CH, CHN 2-30	MG 71	8.7	29	880	450	20/400
		CH, CHN 2-50	MG 80	11.2	13.2	1210	820	25/400
1 x 110/220*	60	CH, CHN 2-20	MG 71	6/2.9	29	680	360	20/400
		CH, CHN 2-30	MG 71	7/2.9	29	800	460	20/400
		CH, CHN 2-50	MG 80	11.2/5.6	13.2	1210	820	25/400
1 x 127	60	CH, CHN 2-30	MG 71	5.9	25	730	480	20/400
		CH, CHN 2-50	MG 80	8.9	35	1100	800	25/400
1 x 220	60	CH, CHN 2-20	MG 71	3.1	15	530	320	20/400
		CH, CHN 2-30	MG 71	3.6	15	880	520	20/400
		CH, CHN 2-40	MG 80	4.7	18	1000	670	25/400
		CH, CHN 2-50	MG 80	5.5	18	1200	930	25/400
		CH, CHN 2-60	MG 80	7.8	21	1300	950	25/400
3 x 220-240/380-415	50	CH, CHN 2-20	MG 71	1.6/0.9	11.4/6.6	380	230	
		CH, CHN 2-30	MG 71	1.7/1	11.4/6.6	460	300	
		CH, CHN 2-40	MG 71	1.9/1.1	11.4/6.6	570	400	
		CH, CHN 2-50	MG 71	2.35/1.25	11.4/6.6	800	560	
		CH, CHN 2-60	MG 71	2.55/1.35	11.4/6.6	820	580	

\* no motor protection

### CH, CHN 2 (USA, Canada)

Voltage [V]	Frequency [Hz]	Pump type	Motor type	SF	$I_{1/1}$ [A]	$I_{st}$ [A]	$P_1^*$ [HP]	C [μF/V]
3 x 208-230/440-480	60	CH 2-20	ML 71	1.70	2.90/1.45	13.9	0.5	
		CH, CHN 2-30	ML 71	1.70	2.90/1.45	15.7	0.5	
		CH, CHN 2-40	ML 71	1.70	4.20/2.10	20.7	0.75	
		CH, CHN 2-50	ML 71	1.70	4.20/2.10	20.7	0.75	
		CH, CHN 2-60	ML 80	1.60	5.20/2.60	32.0	1	
1 x 115/230	60	CH 2-20	ML 71	1.60	9.00/4.50	24.9	0.5	40/400
		CH, CHN 2-30	ML 71	1.60	9.00/4.50	24.9	0.5	40/400
		CH, CHN 2-40	ML 80	1.50	11.5/5.70	34.0	0.75	40/400
		CH, CHN 2-50	ML 80	1.50	11.5/5.70	34.0	0.75	40/400
		CH, CHN 2-60	ML 80	1.50	15.0/7.50	48.0	1	50/400
3 x 575 (Canada)	60	CH 2-20	ML 71	1.70	1.16	5.1	0.5	
		CH, CHN 2-30	ML 71	1.70	1.16	15.7	0.5	
		CH, CHN 2-40	ML 71	1.70	1.68	8.0	0.75	
		CH, CHN 2-50	ML 71	1.70	1.68	8.0	0.75	
		CH, CHN 2-60	ML 80	1.60	2.08	11.2	1	

\*  $P_1$  inclusive of service factor

### CH, CHN 2 (Japan)

Voltage [V]	Frequency [Hz]	Pump type	Motor type	$I_{1/1}$ [A]	$I_{st}$ [A]	$P_1$ [W]	$P_2$ [W]
3 x 200-220/346-380**	50	CH, CHN 2-20	MG 71	2.5/1.6	16.2/14.3	370	230
		CH, CHN 2-30	MG 71	2.5/1.6	16.2/14.3	450	300
		CH, CHN 2-40	MG 80	3.3/2.1	21.6/18.8	590	400
		CH, CHN 2-50	MG 80	3.4/2.1	21.6/18.8	690	490
		CH, CHN 2-60	MG 80	4.0/2.3	30.8/30.8	790	600
3 x 200-230/346-400**	60	CH, CHN 2-20	MG 71	2/1.1	15.7/9.1	520	380
		CH, CHN 2-30	MG 71	2.2/1.3	15.7/9.1	670	510
		CH, CHN 2-40	MG 80	2.8/1.6	20.7/12.0	860	680
		CH, CHN 2-50	MG 80	3.3/1.9	20.7/12.0	1000	820
		CH, CHN 2-60	MG 80	3.9/2.2	32/18.4	1200	980

\*\* Dual frequency pump; can be used for both 50 and 60 Hz in the voltage range stated.

## CH, CHN 4

Voltage [V]	Frequency [Hz]	Pump type	Motor type	I <sub>1/1</sub> [A]	I <sub>st</sub> [A]	P <sub>1</sub> [W]	P <sub>2</sub> [W]	C [μF/V]
1 x 220-240	50	CH, CHN 4-20	MG 71	2.3	11	540	345	16/400
		CH, CHN 4-30	MG 71	3.9	21	840	480	25/400
		CH, CHN 4-40	MG 71	3.9	21	1160	690	25/400
		CH, CHN 4-50	MG 80	5.8	29	1300	920	30/400
		CH, CHN 4-60	MG 80	6.7	29	1460	1050	50/400
1 x 110	60	CH, CHN 4-20	MG 71	8.4	29	950	550	20/400
		CH, CHN 4-30	MG 80	13.8	36	1500	970	25/400
		CH, CHN 4-40	MG 80	15.6	62	1860	1200	30/400
1 x 110/220*	60	CH, CHN 4-20	MG 71	8.8/5.9	29.0/15.0	980	590	20/400
		CH, CHN 4-30	MG 80	13.8/7	36.0/18.0	1520	920	25/400
		CH, CHN 4-40	MG 80	16.0/8.1	62.0/32.0	1720	1220	30/400
1 x 127	60	CH, CHN 4-20	MG 71	7.2	25	920	620	20/400
		CH, CHN 4-30	MG 80	10.8	35	1360	890	25/400
		CH, CHN 4-40	MG 80	14	50	1720	1220	30/400
1 x 220	60	CH, CHN 4-20	MG 71	4.2	15	950	550	20/400
		CH, CHN 4-30	MG 80	7.0	18	1500	970	25/400
		CH, CHN 4-40	MG 80	7.8	32	1860	1200	30/400
3 x 220-240/380-415	50	CH, CHN 4-20	MG 71	1.9/1.0	11.4/6.6	560	390	
		CH, CHN 4-30	MG 71	2.3/1.3	11.4/6.6	820	540	
		CH, CHN 4-40	MG 71	2.8/1.6	11.4/6.6	965	660	
		CH, CHN 4-50	MG 80	4.0/2.3	26.0/15.0	1320	1000	
		CH, CHN 4-60	MG 80	4.4/2.5	26.0/15.0	1510	1170	

\* no motor protection

## CH, CHN 4 (USA, Canada)

Voltage [V]	Frequency [Hz]	Pump type	Motor type	SF	I <sub>1/1</sub> [A]	I <sub>st</sub> [A]	P <sub>1</sub> * [HP]	C [μF/V]
3 x 208-230/440-480	60	CH, CHN 4-20	ML 71	1.70	2.90/1.45	15.7	0.5	
		CH, CHN 4-30	ML 71	1.70	4.20/2.10	20.7	0.75	
		CH, CHN 4-40	ML 80	1.60	5.20/2.60	33.9	1.0	
		CH, CHN 4-50	ML 80	1.47	6.90/3.50	42.0	1.5	
1 x 115/230	60	CH, CHN 4-20	ML 71	1.60	9.00/4.50	24.9	0.5	40/400
		CH, CHN 4-30	ML 71	1.50	11.5/5.70	34.0	0.75	40/400
		CH, CHN 4-40	ML 80	1.50	15.0/7.50	33.9	1.0	50/400
		CH, CHN 4-50	ML 90	1.40	21.5/10.7	33.9	1.5	60/400
3 x 575 (Canada)	60	CH, CHN 4-20	ML 71	1.70	1.16	5.1	0.5	
		CH, CHN 4-30	ML 71	1.70	1.68	8.0	0.75	
		CH, CHN 4-40	ML 80	1.60	2.08	11.2	1.0	
		CH, CHN 4-50	ML 80	1.47	2.80	15.3	1.5	

\* P<sub>1</sub> inclusive of service factor.

## CH, CHN 4 (Japan)

Voltage [V]	Frequency [Hz]	Pump type	Motor type	I <sub>1/1</sub> [A]	I <sub>st</sub> [A]	P <sub>1</sub> [W]	P <sub>2</sub> [W]
3 x 200-220/346-380**	50	CH, CHN 4-20	MG 71	2.6/1.5	16.2/14.3	544	390
		CH, CHN 4-30	MG 80	3.5/2.0	21.6/18.8	808	565
		CH, CHN 4-40	MG 80	4.2/2.4	30.8/30.8	966	771
3 x 200-230/346-400**	60	CH, CHN 4-20	MG 71	2.7/1.5	15.7/9.1	811	616
		CH, CHN 4-30	MG 80	4.0/2.3	20.7/12.0	1261	893
		CH, CHN 4-40	MG 80	4.9/2.8	33.9/19.6	1526	1202

\*\* Dual frequency pump; can be used for both 50 and 60 Hz in the voltage range stated.

## CH 8

Voltage [V]	Frequency [Hz]	Pump type	Motor type	I <sub>1/1</sub> [A]	I <sub>st</sub> [A]	P <sub>1</sub> [W]	P <sub>2</sub> [W]	C [μF/V]
1 x 220-240	50	CH 8-20	MG 71	3.2	11	730	480	16/400
		CH 8-30	MG 80	4.3	13	970	740	20/400
		CH 8-40	MG 80	5.6	26.5	1330	940	25/400
		CH 8-50	MG 90	7.8	29	1740	1310	30/400
		CH 8-60	MG 90	8.5	29	1930	1460	30/400
1 x 220	60	CH 8-20	MG 80	5.4	21	1170	830	25/400
		CH 8-30	MG 90	8.9	40	1920	1350	30/400
		CH 8-40	MG 90	10.4	40	2210	1570	30/400
3 x 220-240/380-415	50	CH 8-20	MG 71	2.1/1.2	11.4/6.6	650	480	
		CH 8-30	MG 80	3.4/2.0	18.2/10.5	1030	790	
		CH 8-40	MG 80	4.7/2.7	27.5/16	1290	1025	
		CH 8-50	MG 80	5.2/3.0	27.5/16	1650	1290	
		CH 8-60	MG 90	5.9/3.4	45/26	1930	1560	

## CH 8 (USA, Canada)

Voltage [V]	Frequency [Hz]	Pump type	Motor type	SF	I <sub>1/1</sub> [A]	I <sub>st</sub> [A]	P <sub>1</sub> * [HP]	C [μF/V]
3 x 208-230/440-480	60	CH 8-20	ML 71	1.70	4.20/2.10	15.6	0.75	
		CH 8-25	ML 80	1.60	5.20/2.60	20.4	1	
		CH 8-30	ML 80	1.47	6.90/3.50	32.0	1.5	
		CH 8-40	ML 80	1.47	6.90/3.50	32.0	1.5	
1 x 115/230	60	CH 8-20	ML 80	1.50	11.5/5.70	34.0	0.75	40/400
		CH 8-25	ML 80	1.50	15.0/7.50	48.0	1	50/400
		CH 8-30	ML 90	1.40	21.5/10.7	83.0	1.5	60/400
		CH 8-40	ML 90	1.40	21.4/10.6	32.0	1.5	60/400
3 x 575 (Canada)	60	CH 8-20	ML 71	1.70	1.68	8.0	0.5	
		CH 8-25	ML 80	1.60	2.08	11.2	1	
		CH 8-30	ML 80	1.47	2.80	15.3	1.5	
		CH 8-40	ML 80	1.47	2.80	15.3	1.5	

\* P<sub>1</sub> inclusive of service factor.

## CH 8 (Japan)

Voltage [V]	Frequency [Hz]	Pump type	Motor type	I <sub>1/1</sub> [A]	I <sub>st</sub> [A]	P <sub>1</sub> [W]	P <sub>2</sub> [W]
3 x 200/346**	50	CH 8-20	MG 71	3.4/2.0	16.2/9.4	714	517
		CH 8-25	MG 80	4.1/2.4	21.6/12.4	891	696
		CH 8-30	MG 80	4.0/2.3	30.0/17.4	1000	830
		CH 8-40	MG 80	4.5/2.5	30.0/17.4	1720	1290
3 x 200-230/346-400**	60	CH 8-20	MG 71	3.5/2.0	15.6/9.0	1084	859
		CH 8-25	MG 80	4.5/2.6	20.4/11.8	1418	1152
		CH 8-30	MG 80	5.9/3.4	32.0/18.4	1830	1400
		CH 8-40	MG 80	7.6/4.4	32.0/18.8	2260	1620
3 x 200/346	50	CH 8-50	MG 80	5.7/3.3	30.0/17.4	1720	1290
		CH 8-60	MG 80	6.0/3.5	30.0/17.4	1850	1370

\*\* Dual frequency pump; can be used for both 50 and 60 Hz in the voltage range stated.



## CH 12

Voltage [V]	Frequency [Hz]	Pump type	Motor type	I <sub>1/1</sub> [A]	I <sub>st</sub> [A]	P <sub>1</sub> [W]	P <sub>2</sub> [W]	C [μF/V]
1 x 220-240	50	CH 12-20	MG 80	4.8	13	1060	710	20/400
		CH 12-30	MG 80	6.8	26.7	1520	1080	25/400
		CH 12-40	MG 90	9.6	42	2180	1642	50/400
		CH 12-50	MG 90	11.3	42	2560	1630	50/400
1 x 220	60	CH 12-20	MG 90	9.2	40	1980	1430	30/400
3 x 220-240/380-415	50	CH 12-20	MG 80	3.2/1.8	18.2/10.5	1030	790	
		CH 12-30	MG 80	4.3/2.5	26.0/15.0	1530	1190	
		CH 12-40	MG 90	6.6/3.8	45.0/26.0	2200	1770	
		CH 12-50	MG 90	8.1/4.8	57.0/33.0	2690	2150	
		CH 12-60	MG 90	9.4/5.5	57.0/33.0	3180	2560	

## CH 12 (USA, Canada)

Voltage [V]	Frequency [Hz]	Pump type	Motor type	SF	I <sub>1/1</sub> [A]	I <sub>st</sub> [A]	P <sub>1</sub> * [HP]	C [μF/V]
3 x 208-230/440-480	60	CH 12-10	ML 71	1.70	2.90/1.45	15.7	0.5	
		CH 12-20	ML 80	1.47	6.90/3.50	32.0	1.5	
		CH 12-30	ML 90	1.50	9.10/4.75	46.0	2	
1 x 115/230	60	CH 12-10	ML 71	1.60	9.00/4.50	24.9	0.5	40/400
		CH 12-20	ML 90	1.40	21.5/10.7	83.0	1.5	60/400
3 x 575 (Canada)	60	CH 12-10	ML 71	1.70	1.16	5.1	0.5	
		CH 12-20	ML 80	1.47	2.80	15.3	1.5	
		CH 12-30	ML 90	1.50	3.80	28.0	2	

\* P<sub>1</sub> inclusive of service factor.

## CH 12 (Japan)

Voltage [V]	Frequency [Hz]	Pump type	Motor type	I <sub>1/1</sub> [A]	I <sub>st</sub> [A]	P <sub>1</sub> [W]	P <sub>2</sub> [W]
3 x 200/346**	50	CH 12-10	MG 71	3.3/1.9	3.3/1.9	550	375
		CH 12-20	MG 80	3.1/1.8	3.1/1.8	880	670
		CH 12-30	MG 90	7.0/4.0	7.0/4.0	1600	1280
		CH 12-40	MG 90	9.9/5.7	9.9/5.7	1720	1290
3 x 200-230/346-400**	60	CH 12-10	MG 71	2.75/1.6	2.75/1.6	820	650
		CH 12-20	MG 80	5.7/3.3	5.7/3.3	1770	1360
		CH 12-30	MG 90	8.6/5.0	8.6/5.0	2680	2130
		CH 12-40	MG 90	11.6/6.7	11.6/6.7	3500	2740
3 x 200/346	50	CH 12-50	MG 90	8.5/4.9	8.5/4.9	2600	2200
		CH 12-60	MG 90	11.4/6.5	11.4/6.5	3500	2700

\*\* Dual frequency pump; can be used for both 50 and 60 Hz in the voltage range stated.

## Dimensions

### CH, CHN 2 and 4 with MG 71/80 motor

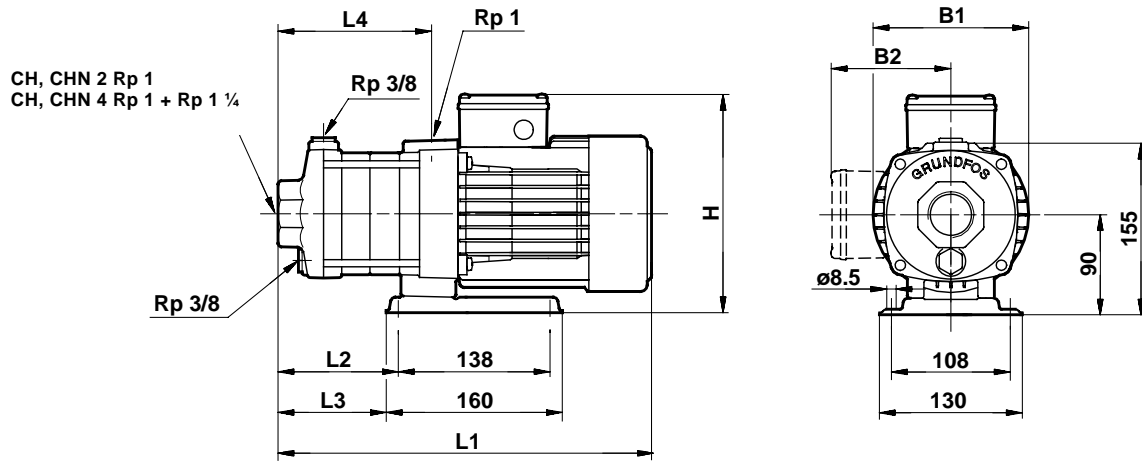

Fig. 6 Dimensional sketches CH, CHN 2 and 4 with MG 71/80 motor

TM00 1491 4900

# Dimensions and weights

CH, CHN

## CH, CHN 2

Voltage [V]	Frequency [Hz]	Pump type	Motor type	L1 [mm]	L2 [mm]	L3 [mm]	L4 [mm]	B1 [mm]	B2 [mm]	H [mm]
1 x 220-240	50	CH, CHN 2-20	MG 71	304	74	63	99	146	115	205
		CH, CHN 2-30	MG 71	322	92	81	117	146	115	205
		CH, CHN 2-40	MG 71	340	110	99	135	146	115	205
		CH, CHN 2-50	MG 71	358	128	117	154	146	115	205
		CH, CHN 2-60	MG 71	376	146	135	172	146	115	205
1 x 110	60	CH, CHN 2-20	MG 71	304	74	63	99	141.5	135	225
		CH, CHN 2-30	MG 71	322	92	81	117	141.5	135	225
		CH, CHN 2-50	MG 80	398	128	117	154	141.5	135	225
1 x 110/220*	60	CH, CHN 2-20	MG 71	304	74	63	99	141.5	135	225
		CH, CHN 2-30	MG 71	322	92	81	117	141.5	135	225
		CH, CHN 2-50	MG 80	398	128	117	154	141.5	135	225
1 x 127	60	CH, CHN 2-30	MG 71	322	92	81	117	141.5	135	225
		CH, CHN 2-50	MG 80	398	128	117	154	141.5	135	225
1 x 220	60	CH, CHN 2-20	MG 71	304	74	63	99	141.5	135	225
		CH, CHN 2-30	MG 71	322	92	81	117	141.5	135	225
		CH, CHN 2-40	MG 80	380	110	99	135	141.5	135	225
		CH, CHN 2-50	MG 80	398	128	117	154	141.5	135	225
		CH, CHN 2-60	MG 80	416	146	135	172	141.5	135	225
3 x 220-240/380-415	50	CH, CHN 2-20	MG 71	304	74	63	99	146	110	200
		CH, CHN 2-30	MG 71	322	92	81	117	146	110	200
		CH, CHN 2-40	MG 71	340	110	99	135	146	110	200
		CH, CHN 2-50	MG 71	358	128	117	154	146	110	200
		CH, CHN 2-60	MG 71	376	146	135	172	146	110	200

\* No motor protection

## CH, CHN 2 (USA/Canada)

Voltage [V]	Frequency [Hz]	Pump type	Motor type	L1 [mm]	L2 [mm]	L3 [mm]	L4 [mm]	B1 [mm]	B2 [mm]	H [mm]
3 x 208-230/440-480	60	CH, CHN 2-20	MG 71	304	74	63	99	146	110	200
		CH, CHN 2-30	MG 71	322	92	81	117	146	110	200
		CH, CHN 2-40	MG 71	382	110	99	135	146	110	200
		CH, CHN 2-50	MG 71	400	128	117	154	146	110	200
		CH, CHN 2-60	MG 80	417	146	135	172	141.5	115	200
1 x 115/230	60	CH, CHN 2-30	MG 71	322	92	81	117	146	145	226
		CH, CHN 2-40	MG 80	381	110	99	135	141.5	145	226
		CH, CHN 2-50	MG 80	399	128	117	154	141.5	145	226
		CH, CHN 2-60	MG 90	416	146	135	172	141.5	145	226
3 x 575 (Canada)	60	CH, CHN 2-20	MG 71	304	74	63	99	146	110	225
		CH, CHN 2-30	MG 71	322	92	81	117	146	110	225
		CH, CHN 2-40	MG 71	382	110	99	135	146	110	225
		CH, CHN 2-50	MG 71	400	128	117	154	146	110	225
		CH, CHN 2-60	MG 80	417	146	135	172	141.5	115	225

## CH, CHN 2 (Japan)

Voltage [V]	Frequency [Hz]	Pump type	Motor type	L1 [mm]	L2 [mm]	L3 [mm]	L4 [mm]	B1 [mm]	B2 [mm]	H [mm]
3 x 200-220/346-380 3 x 200-230/346-400	50	CH, CHN 2-20	MG 71	304	74	63	99	141.5	110	200
		CH, CHN 2-30	MG 71	322	92	81	117	141.5	110	200
	60	CH, CHN 2-40	MG 80	380	110	99	135	141.5	110	200
		CH, CHN 2-50	MG 80	398	128	117	154	141.5	110	200
		CH, CHN 2-60	MG 80	416	146	135	172	141.5	110	200

# Dimensions and weights

CH, CHN

## CH, CHN 4

Voltage [V]	Frequency [Hz]	Pump type	Motor type	L1 [mm]	L2 [mm]	L3 [mm]	L4 [mm]	B1 [mm]	B2 [mm]	H [mm]
1 x 220-240	50	CH, CHN 4-20	MG 71	314	83	72	108	146	115	205
		CH, CHN 4-30	MG 71	342	110	99	135	146	115	205
		CH, CHN 4-40	MG 71	370	137	126	163	146	115	205
		CH, CHN 4-50	MG 80	438	164	153	190	141.5	135	225
		CH, CHN 4-60	MG 80	466	191	180	217	141.5	135	225
1 x 110	60	CH, CHN 4-20	MG 71	314	83	72	108	141.5	135	225
		CH, CHN 4-30	MG 80	382	110	99	135	141.5	135	225
		CH, CHN 4-40	MG 80	410	137	126	163	141.5	135	225
1 x 110/220*	60	CH, CHN 4-20	MG 71	314	83	72	108	141.5	135	225
		CH, CHN 4-30	MG 80	382	110	99	135	141.5	135	225
		CH, CHN 4-40	MG 80	410	137	126	163	141.5	135	225
1 x 127	60	CH, CHN 4-20	MG 71	314	83	72	108	141.5	135	225
		CH, CHN 4-30	MG 80	382	110	99	135	141.5	135	225
		CH, CHN 4-40	MG 80	410	137	126	163	141.5	135	225
1 x 220	60	CH, CHN 4-20	MG 71	314	83	72	108	141.5	135	225
		CH, CHN 4-30	MG 80	382	110	99	135	141.5	135	225
		CH, CHN 4-40	MG 80	410	137	126	163	141.5	135	225
3 x 220-240/380-415	50	CH, CHN 4-20	MG 71	314	83	72	108	146	115	200
		CH, CHN 4-30	MG 71	342	110	99	135	146	110	200
		CH, CHN 4-40	MG 71	370	137	126	163	146	110	200
		CH, CHN 4-50	MG 80	438	164	153	190	141.5	110	200
		CH, CHN 4-60	MG 80	466	191	180	217	141.5	110	200

\* No motor protection

## CH, CHN 4 (USA/Canada)

Voltage [V]	Frequency [Hz]	Pump type	Motor type	L1 [mm]	L2 [mm]	L3 [mm]	L4 [mm]	B1 [mm]	B2 [mm]	H [mm]
3 x 208-230/440-480	60	CH, CHN 4-20	MG 71	314	83	72	108	146	110	200
		CH, CHN 4-30	MG 71	382	110	99	135	146	110	200
		CH, CHN 4-40	MG 80	411	137	126	163	141.5	115	200
		CH, CHN 4-50	MG 80	439	164	153	190	141.5	115	200
1 x 115/230	60	CH, CHN 4-20	MG 71	314	83	72	108	146	110	226
		CH, CHN 4-30	MG 71	342	83	72	108	146	145	226
		CH, CHN 4-40	MG 80	411	110	99	135	141.5	145	226
		CH, CHN 4-50	MG 80	439	137	126	163	141.5	145	226
		CH, CHN 4-60	MG 90	504	164	153	190	191	132	205
3 x 575 (Canada)	60	CH, CHN 4-20	MG 71	314	83	72	108	146	110	200
		CH, CHN 4-30	MG 71	342	83	72	108	146	110	200
		CH, CHN 4-40	MG 71	370	110	99	135	146	110	200
		CH, CHN 4-50	MG 80	439	137	126	163	141.5	115	200
		CH, CHN 4-60	MG 80	467	164	153	190	141.5	115	200

## CH, CHN 4 (Japan)

Voltage [V]	Frequency [Hz]	Pump type	Motor type	L1 [mm]	L2 [mm]	L3 [mm]	L4 [mm]	B1 [mm]	B2 [mm]	H [mm]
3 x 200-220/346-380	50	CH, CHN 4-20	MG 71	314	83	72	108	141.5	110	200
3 x 200-230/346-400	60	CH, CHN 4-30	MG 80	382	110	99	135	141.5	110	200
		CH, CHN 4-40	MG 80	410	137	126	163	141.5	110	200

## CH 8 and 12 with MG 80 motor

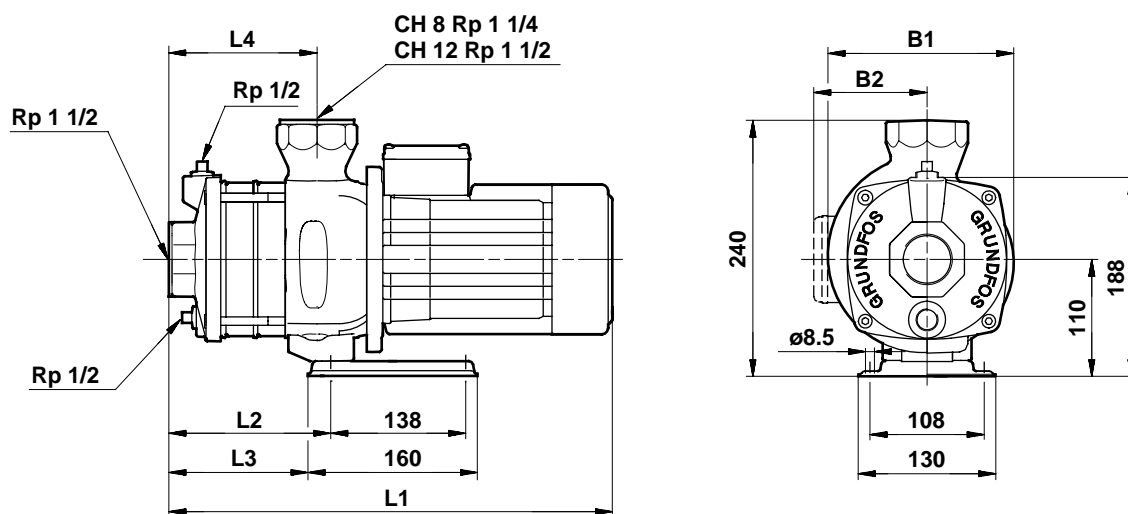

Fig. 7 Dimensional sketches CH, CHN 8 and 12 with MG 80 motor

## CH 8 and 12 with MG 90 motor

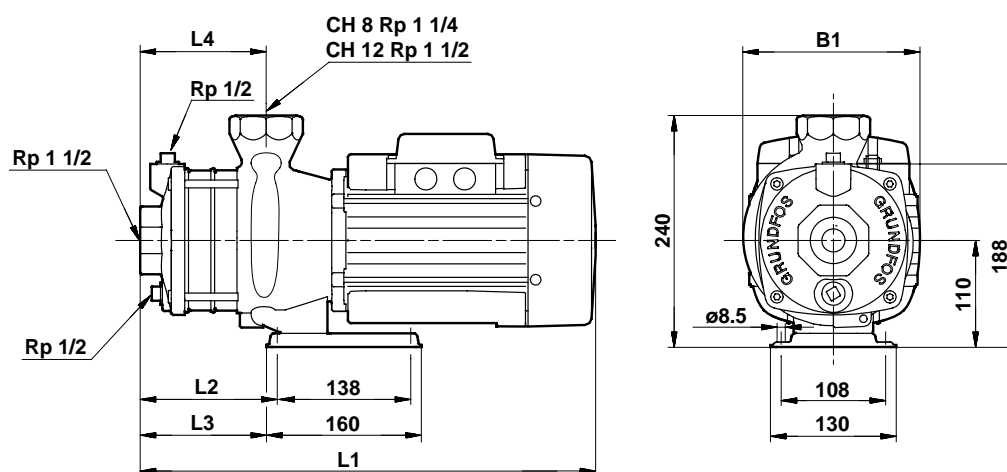

Fig. 8 Dimensional sketches CH, CHN 8 and 12 with MG 90 motor

TM00 1189 3505

TM00 1490 3505

# Dimensions and weights

CH, CHN

## CH 8

Voltage [V]	Frequency [Hz]	Pump type	Motor type	L1 [mm]	L2 [mm]	L3 [mm]	L4 [mm]	B1 [mm]	B2 [mm]
1 x 220-240	50	CH 8-20	MG 71	311	69	58	77	177	109
		CH 8-30	MG 80	381	99	88	107	177	109
		CH 8-40	MG 80	381	99	88	107	177	109
		CH 8-50	MG 90	459	129	118	137	182	
		CH 8-60	MG 90	459	129	118	137	182	
1 x 220	60	CH 8-20	MG 80	351	69	58	77	177	109
		CH 8-30	MG 90	429	99	88	107	182	
		CH 8-40	MG 90	429	99	88	107	182	
3 x 220-240/380-415	50	CH 8-20	MG 71	311	69	58	77	177	109
		CH 8-30	MG 80	381	99	88	107	177	109
		CH 8-40	MG 80	381	99	88	107	177	109
		CH 8-50	MG 80	411	129	118	137	177	109
		CH 8-60	MG 90	459	129	118	137	182	

## CH 8 (USA/Canada)

Voltage [V]	Frequency [Hz]	Pump type	Motor type	L1 [mm]	L2 [mm]	L3 [mm]	L4 [mm]	B1 [mm]	B2 [mm]	H [mm]
3 x 208-230/440-480	60	CH 8-20	MG 71	311	69	58	77	177	109	200
		CH 8-25	MG 80	381	99	88	107	177	109	200
		CH 8-30	MG 80	381	99	88	107	177	109	200
		CH 8-40	MG 80	381	99	88	107	177	109	200
1 x 115/230	60	CH 8-20	MG 80	351	69	58	77	177	124	226
		CH 8-25	MG 80	381	99	88	107	177	124	226
		CH 8-30	MG 90	429	99	88	107	191	132	220
		CH 8-40	MG 90	429	99	88	107	191	132	220
3 x 575 (Canada)	60	CH 8-20	MG 71	311	69	58	77	177	109	240
		CH 8-25	MG 80	381	99	88	107	177	109	240
		CH 8-30	MG 80	381	99	88	107	177	109	240
		CH 8-40	MG 80	381	99	88	107	177	109	240

## CH 8 (Japan)

Voltage [V]	Frequency [Hz]	Pump type	Motor type	L1 [mm]	L2 [mm]	L3 [mm]	L4 [mm]	B1 [mm]	B2 [mm]
3 x 200/346 3 x 200-220/346-400	50	CH 8-20	MG 71	311	69	58	77	177	109
		CH 8-25	MG 80	381	99	88	107	177	109
	60	CH 8-30	MG 80	381	99	88	107	177	109
		CH 8-40	MG 80	381	99	88	107	177	109
3 x 200/346	50	CH 8-50	MG 80	411	129	118	137	177	109
		CH 8-60	MG 80	411	129	118	137	177	109

# Dimensions and weights

CH, CHN

## CH 12

Voltage [V]	Frequency [Hz]	Pump type	Motor type	L1 [mm]	L2 [mm]	L3 [mm]	L4 [mm]	B1 [mm]	B2 [mm]
1 x 220-240	50	CH 12-20	MG 80	351	69	58	77	177	109
		CH 12-30	MG 80	381	99	88	107	177	109
		CH 12-40	MG 90	429	99	88	107	182	
		CH 12-50	MG 90	459	129	118	137	182	
1 x 220	60	CH 12-20	MG 90	399	69	58	77	182	
3 x 220-240/380-415	50	CH 12-20	MG 80	351	69	58	77	177	109
		CH 12-30	MG 80	381	99	88	107	177	109
		CH 12-40	MG 90	429	99	88	107	182	
		CH 12-50	MG 90	459	129	118	137	182	
		CH 12-60	MG 90	459	129	118	137	182	

## CH 12 (USA/Canada)

Voltage [V]	Frequency [Hz]	Pump type	Motor type	L1 [mm]	L2 [mm]	L3 [mm]	L4 [mm]	B1 [mm]	B2 [mm]	H [mm]
3 x 208-230/440-480	60	CH 12-10	MG 71	311	69	58	77	177	109	240
		CH 12-20	MG 80	351	69	58	77	177	109	240
		CH 12-30	MG 90	429	99	88	107	186	124	220
1 x 115/230	60	CH 12-10	MG 71	311	69	58	77	177		226
		CH 12-20	MG 90	399	69	58	77	191	132	220
3 x 575 (Canada)	60	CH 12-10	MG 71	311	69	58	77	177	109	240
		CH 12-20	MG 80	351	69	58	77	177	109	240
		CH 12-30	MG 90	429	99	88	107	186	124	220

## CH 12 (Japan)

Voltage [V]	Frequency [Hz]	Pump type	Motor type	L1 [mm]	L2 [mm]	L3 [mm]	L4 [mm]	B1 [mm]	B2 [mm]
3 x 200/346 3 x 200-220/346-380	50	CH 12-10	MG 71	311	69	58	77	177	109
		CH 12-20	MG 80	351	69	58	77	177	109
	60	CH 12-30	MG 90	429	99	88	107	182	
		CH 12-40	MG 90	429	99	88	107	182	
3 x 200/346	50	CH 12-50	MG 90	459	129	118	137	182	110
		CH 12-60	MG 90	459	129	118	137	182	110

## Weights

### CH, CHN, single-phase

Pump type	50 Hz			60 Hz		
	Net weight [kg]	Gross weight [kg]	Shipping volume [m³]	Net weight [kg]	Gross weight [kg]	Shipping volume [m³]
CH, CHN 2-20	9.6	11.4	0.0187	12.8	13.5	0.0187
CH, CHN 2-30	9.6	11.4	0.0187	12.8	13.5	0.0187
CH, CHN 2-40	10.9	11.5	0.0187	13	13.7	0.0235
CH, CHN 2-50	11.3	12.0	0.0235	13.3	14	0.0235
CH, CHN 2-60	11.6	12.3	0.0235	14.6	16.2	0.0235
CH, CHN 4-20	9.5	10.1	0.0187	12	12.7	0.0187
CH, CHN 4-30	10.9	11.6	0.0187	13.4	14.1	0.0235
CH, CHN 4-40	12.3	13.0	0.0235	14.2	15.2	0.0235
CH, CHN 4-50	16	17.7	0.0235	-	-	-
CH, CHN 4-60	15.2	16.6	0.0235	-	-	-
CH 8-20	15	17	0.0422	18	20	0.0422
CH 8-25	-	-	-	19	21	0.0422
CH 8-30	17	19	0.0422	26	28	0.0422
CH 8-40	19	21	0.0422	26	28	0.0422
CH 8-50	28.8	31.6	0.0422	-	-	-
CH 8-60	28.8	31.6	0.0422	-	-	-
CH 12-10	-	-	-	15	17	0.0422
CH 12-20	17	19	0.0422	27	29	0.0422
CH 12-30	19	21	0.0422	-	-	-
CH 12-40	26	28	0.0422	-	-	-
CH 12-50	27	29	0.0422	-	-	-
CH 12-60	-	-	-	-	-	-

### CH, CHN, three-phase

Pump type	50 Hz			60 Hz and 50/60 Hz		
	Net weight [kg]	Gross weight [kg]	Shipping volume [m³]	Net weight [kg]	Gross weight [kg]	Shipping volume [m³]
CH, CHN 2-20	11.1	11.8	0.0187	11.1	11.8	0.0187
CH, CHN 2-30	10.7	11.6	0.0187	11.1	11.8	0.0187
CH, CHN 2-40	11.0	11.7	0.0187	11.3	11.9	0.0187
CH, CHN 2-50	11.5	12.2	0.0235	11.5	12.5	0.0235
CH, CHN 2-60	11.8	12.5	0.0235	12.0	13.0	0.0235
CH, CHN 4-20	9.6	10.3	0.0187	10.9	11.6	0.0187
CH, CHN 4-30	11.0	11.7	0.0187	12.3	13.0	0.0235
CH, CHN 4-40	12.5	13.2	0.0235	13.8	14.5	0.0235
CH, CHN 4-50	14.2	14.9	0.0422	-	-	-
CH, CHN 4-60	14.9	16.3	0.0422	-	-	-
CH 8-20	15	17	0.0422	15.7	18.5	0.0422
CH 8-25	-	-	-	17.0	19.8	0.0422
CH 8-30	17	19	0.0422	18.7	21.5	0.0422
CH 8-40	19	21	0.0422	19.0	21.8	0.0422
CH 8-50	20	22	0.0422	-	-	-
CH 8-60	25	27	0.0422	-	-	-
CH 12-10	-	-	-	15.7	18.5	0.0422
CH 12-20	17	19	0.0422	18.8	21.6	0.0422
CH 12-30	19	21	0.0422	26.1	28.9	0.0422
CH 12-40	24	26	0.0422	28.9	31.7	0.0422
CH 12-50	27	29	0.0422	-	-	-
CH 12-60	27	29	0.0422	-	-	-



## WebCAPS

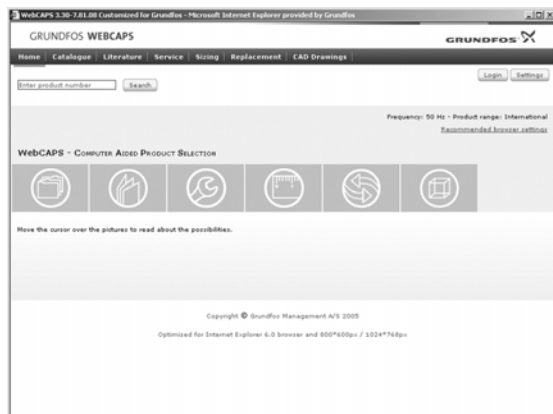

WebCAPS is a **Web-based Computer Aided Product Selection** program available on [www.grundfos.com](http://www.grundfos.com).

WebCAPS contains detailed information on more than 185,000 Grundfos products in more than 22 languages.

In WebCAPS, all information is divided into 6 sections:

- Catalogue
- Literature
- Service
- Sizing
- Replacement
- CAD drawings.

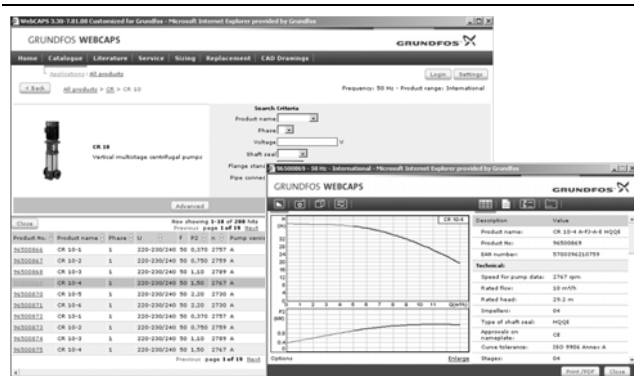

### Catalogue

This section is based on fields of application and pump types, and contains

- technical data
- curves (QH, Eta, P1, P2, etc) which can be adapted to the density and viscosity of the pumped liquid and show the number of pumps in operation
- product photos
- dimensional drawings
- wiring diagrams
- quotation texts, etc.

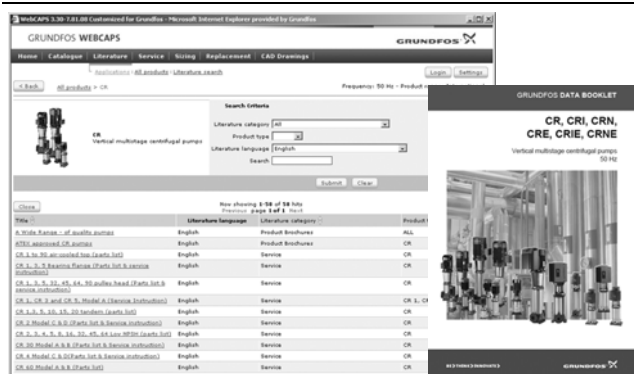

### Literature

In this section you can access all the latest documents of a given pump, such as

- data booklets
- installation and operating instructions
- service documentation, such as Service kit catalogue and Service kit instructions
- quick guides
- product brochures, etc.

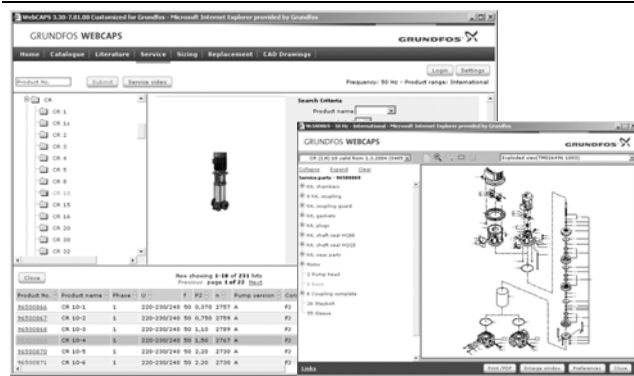

### Service

This section contains an easy-to-use interactive service catalogue. Here you can find and identify service parts of both existing and discontinued Grundfos pumps. Furthermore, this section contains service videos showing you how to replace service parts.



## Sizing

This section is based on different fields of application and installation examples, and gives easy step-by-step instructions in how to

- select the most suitable and efficient pump for your installation
- carry out advanced calculations based on energy consumption, payback periods, load profiles, life cycle costs, etc.
- analyse your selected pump via the built-in life cycle cost tool
- determine the flow velocity in wastewater applications, etc.



## Replacement

In this section you find a guide to selecting and comparing replacement data of an installed pump in order to replace the pump with a more efficient Grundfos pump. The section contains replacement data of a wide range of pumps produced by other manufacturers than Grundfos.

Based on an easy step-by-step guide, you can compare Grundfos pumps with the one you have installed on your site. When you have specified the installed pump, the guide will suggest a number of Grundfos pumps which can improve both comfort and efficiency.



## CAD drawings

In this section it is possible to download 2-dimensional (2D) and 3-dimensional (3D) CAD drawings of most Grundfos pumps.

These formats are available in WebCAPS:

- 2-dimensional drawings:
- .dxf, wireframe drawings
  - .dwg, wireframe drawings.
- 3-dimensional drawings:
- .dwg, wireframe drawings (without surfaces)
  - .stp, solid drawings (with surfaces)
  - .eprt, E-drawings.

## WinCAPS



Fig. 9 WinCAPS CD-ROM

WinCAPS is a **Windows-based Computer Aided Product Selection** program containing detailed information on more than 185,000 Grundfos products in more than 22 languages.

The program contains the same features and functions as WebCAPS, but is an ideal solution if no Internet connection is available.

WinCAPS is available on CD-ROM and updated once a year.



<b>V7173560</b> 0706	<b>GB</b>
Repl. V7173560 0106	

Subject to alterations.